

OCR Maths C3

Past Paper Pack

2005-2014

- 1 The function f is defined for all real values of x by

$$f(x) = 10 - (x + 3)^2.$$

(i) State the range of f . [1]

(ii) Find the value of $ff(-1)$. [3]

- 2 Find the exact solutions of the equation $|6x - 1| = |x - 1|$. [4]

- 3 The mass, m grams, of a substance at time t years is given by the formula

$$m = 180e^{-0.017t}.$$

(i) Find the value of t for which the mass is 25 grams. [3]

(ii) Find the rate at which the mass is decreasing when $t = 55$. [3]

- 4 (a)

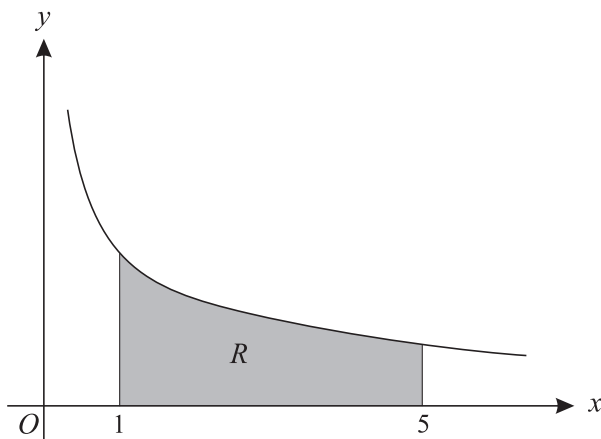

The diagram shows the curve $y = \frac{2}{\sqrt{x}}$. The region R , shaded in the diagram, is bounded by the curve and by the lines $x = 1$, $x = 5$ and $y = 0$. The region R is rotated completely about the x -axis. Find the exact volume of the solid formed. [4]

- (b) Use Simpson's rule, with 4 strips, to find an approximate value for

$$\int_1^5 \sqrt{x^2 + 1} \, dx,$$

giving your answer correct to 3 decimal places. [4]

- 5 (i) Express $3 \sin \theta + 2 \cos \theta$ in the form $R \sin(\theta + \alpha)$, where $R > 0$ and $0^\circ < \alpha < 90^\circ$. [3]

(ii) Hence solve the equation $3 \sin \theta + 2 \cos \theta = \frac{7}{2}$, giving all solutions for which $0^\circ < \theta < 360^\circ$. [5]

June 2005

- 6 (a) Find the exact value of the x -coordinate of the stationary point of the curve $y = x \ln x$. [4]
- (b) The equation of a curve is $y = \frac{4x + c}{4x - c}$, where c is a non-zero constant. Show by differentiation that this curve has no stationary points. [3]
- 7 (i) Write down the formula for $\cos 2x$ in terms of $\cos x$. [1]
- (ii) Prove the identity $\frac{4 \cos 2x}{1 + \cos 2x} \equiv 4 - 2 \sec^2 x$. [3]
- (iii) Solve, for $0 < x < 2\pi$, the equation $\frac{4 \cos 2x}{1 + \cos 2x} = 3 \tan x - 7$. [5]

8

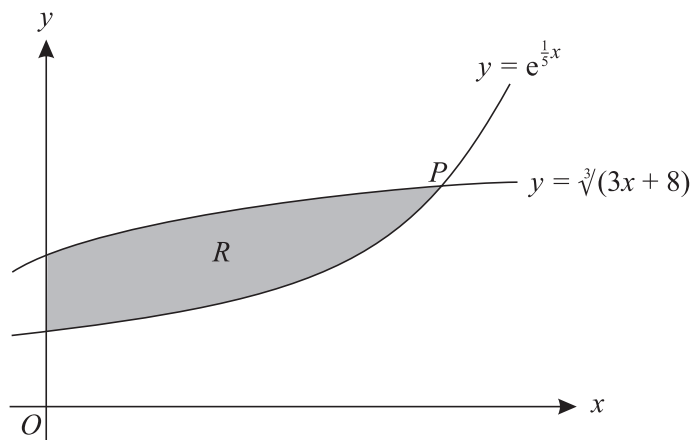

The diagram shows part of each of the curves $y = e^{\frac{1}{5}x}$ and $y = \sqrt[3]{(3x + 8)}$. The curves meet, as shown in the diagram, at the point P . The region R , shaded in the diagram, is bounded by the two curves and by the y -axis.

- (i) Show by calculation that the x -coordinate of P lies between 5.2 and 5.3. [3]
- (ii) Show that the x -coordinate of P satisfies the equation $x = \frac{5}{3} \ln(3x + 8)$. [2]
- (iii) Use an iterative formula, based on the equation in part (ii), to find the x -coordinate of P correct to 2 decimal places. [3]
- (iv) Use integration, and your answer to part (iii), to find an approximate value of the area of the region R . [5]

[Question 9 is printed overleaf.]

9

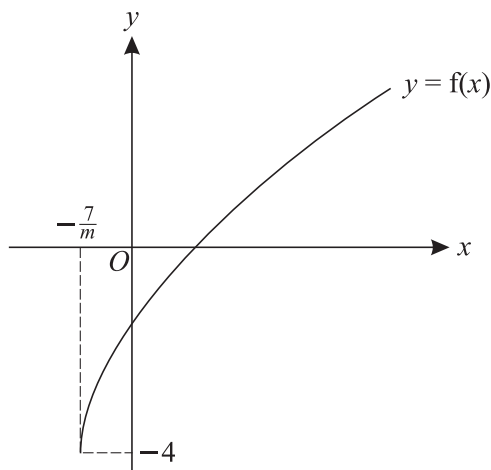

The function f is defined by $f(x) = \sqrt{mx + 7} - 4$, where $x \geq -\frac{7}{m}$ and m is a positive constant. The diagram shows the curve $y = f(x)$.

- (i) A sequence of transformations maps the curve $y = \sqrt{x}$ to the curve $y = f(x)$. Give details of these transformations. [4]
- (ii) Explain how you can tell that f is a one-one function and find an expression for $f^{-1}(x)$. [4]
- (iii) It is given that the curves $y = f(x)$ and $y = f^{-1}(x)$ do not meet. Explain how it can be deduced that neither curve meets the line $y = x$, and hence determine the set of possible values of m . [5]

Jan 2006

1 Show that $\int_2^8 \frac{3}{x} dx = \ln 64$. [4]

2 Solve, for $0^\circ < \theta < 360^\circ$, the equation $\sec^2 \theta = 4 \tan \theta - 2$. [5]

3 (a) Differentiate $x^2(x+1)^6$ with respect to x . [3]

(b) Find the gradient of the curve $y = \frac{x^2 + 3}{x^2 - 3}$ at the point where $x = 1$. [3]

4

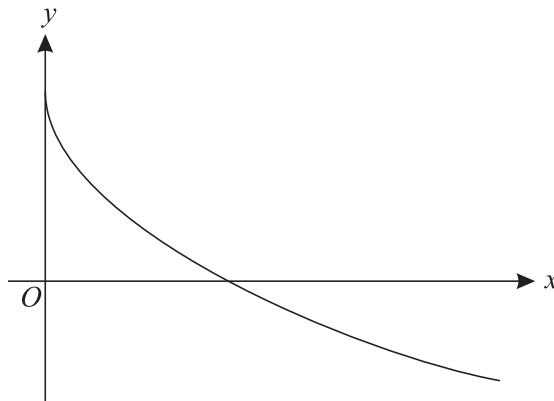

The function f is defined by $f(x) = 2 - \sqrt{x}$ for $x \geq 0$. The graph of $y = f(x)$ is shown above.

(i) State the range of f . [1]

(ii) Find the value of $ff(4)$. [2]

(iii) Given that the equation $|f(x)| = k$ has two distinct roots, determine the possible values of the constant k . [2]

5

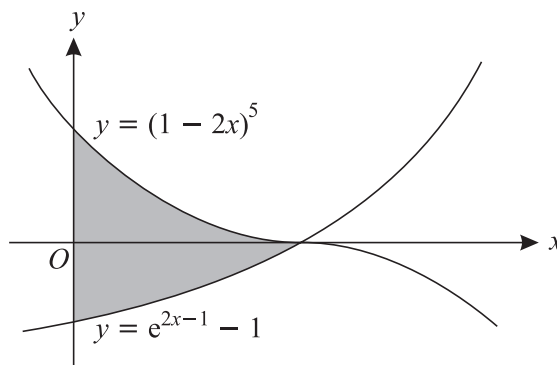

The diagram shows the curves $y = (1 - 2x)^5$ and $y = e^{2x-1} - 1$. The curves meet at the point $(\frac{1}{2}, 0)$. Find the exact area of the region (shaded in the diagram) bounded by the y -axis and by part of each curve. [8]

Jan 2006

6 (a)

t	0	10	20
X	275	440	

The quantity X is increasing exponentially with respect to time t . The table above shows values of X for different values of t . Find the value of X when $t = 20$. [3]

(b) The quantity Y is decreasing exponentially with respect to time t where

$$Y = 80e^{-0.02t}.$$

(i) Find the value of t for which $Y = 20$, giving your answer correct to 2 significant figures. [3]

(ii) Find by differentiation the rate at which Y is decreasing when $t = 30$, giving your answer correct to 2 significant figures. [3]

7

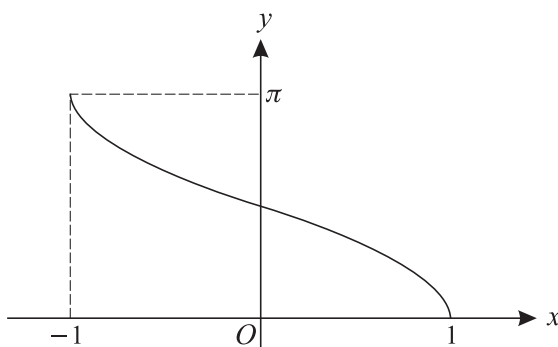

The diagram shows the curve with equation $y = \cos^{-1} x$.

(i) Sketch the curve with equation $y = 3 \cos^{-1}(x - 1)$, showing the coordinates of the points where the curve meets the axes. [3]

(ii) By drawing an appropriate straight line on your sketch in part (i), show that the equation $3 \cos^{-1}(x - 1) = x$ has exactly one root. [1]

(iii) Show by calculation that the root of the equation $3 \cos^{-1}(x - 1) = x$ lies between 1.8 and 1.9. [2]

(iv) The sequence defined by

$$x_1 = 2, \quad x_{n+1} = 1 + \cos\left(\frac{1}{3}x_n\right)$$

converges to a number α . Find the value of α correct to 2 decimal places and explain why α is the root of the equation $3 \cos^{-1}(x - 1) = x$. [5]

[Questions 8 and 9 are printed overleaf.]

Jan 2006

8

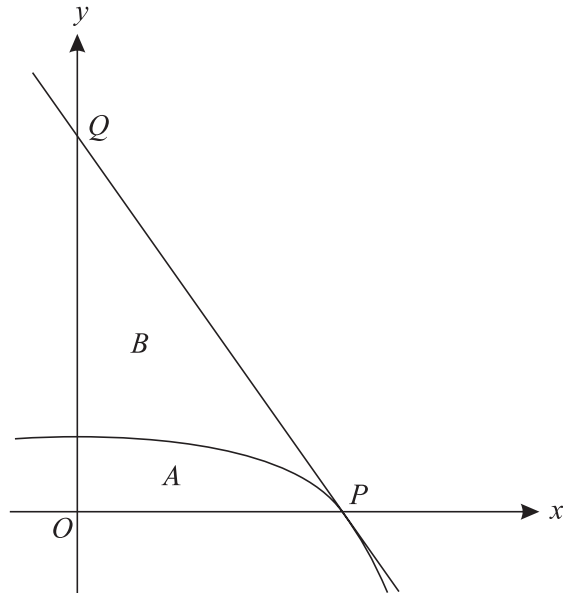

The diagram shows part of the curve $y = \ln(5 - x^2)$ which meets the x -axis at the point P with coordinates $(2, 0)$. The tangent to the curve at P meets the y -axis at the point Q . The region A is bounded by the curve and the lines $x = 0$ and $y = 0$. The region B is bounded by the curve and the lines PQ and $x = 0$.

(i) Find the equation of the tangent to the curve at P . [5]

(ii) Use Simpson's Rule with four strips to find an approximation to the area of the region A , giving your answer correct to 3 significant figures. [4]

(iii) Deduce an approximation to the area of the region B . [2]

9 (i) By first writing $\sin 3\theta$ as $\sin(2\theta + \theta)$, show that

$$\sin 3\theta = 3 \sin \theta - 4 \sin^3 \theta. \quad [4]$$

(ii) Determine the greatest possible value of

$$9 \sin\left(\frac{10}{3}\alpha\right) - 12 \sin^3\left(\frac{10}{3}\alpha\right),$$

and find the smallest positive value of α (in degrees) for which that greatest value occurs. [3]

(iii) Solve, for $0^\circ < \beta < 90^\circ$, the equation $3 \sin 6\beta \operatorname{cosec} 2\beta = 4$. [6]

- 1 Find the equation of the tangent to the curve $y = \sqrt{4x + 1}$ at the point (2, 3). [5]
- 2 Solve the inequality $|2x - 3| < |x + 1|$. [5]
- 3 The equation $2x^3 + 4x - 35 = 0$ has one real root.
- (i) Show by calculation that this real root lies between 2 and 3. [3]
- (ii) Use the iterative formula
- $$x_{n+1} = \sqrt[3]{17.5 - 2x_n},$$
- with a suitable starting value, to find the real root of the equation $2x^3 + 4x - 35 = 0$ correct to 2 decimal places. You should show the result of each iteration. [3]
- 4 It is given that $y = 5^{x-1}$.
- (i) Show that $x = 1 + \frac{\ln y}{\ln 5}$. [2]
- (ii) Find an expression for $\frac{dx}{dy}$ in terms of y . [2]
- (iii) Hence find the exact value of the gradient of the curve $y = 5^{x-1}$ at the point (3, 25). [2]
- 5 (i) Write down the identity expressing $\sin 2\theta$ in terms of $\sin \theta$ and $\cos \theta$. [1]
- (ii) Given that $\sin \alpha = \frac{1}{4}$ and α is acute, show that $\sin 2\alpha = \frac{1}{8}\sqrt{15}$. [3]
- (iii) Solve, for $0^\circ < \beta < 90^\circ$, the equation $5 \sin 2\beta \sec \beta = 3$. [3]

June 2006

6

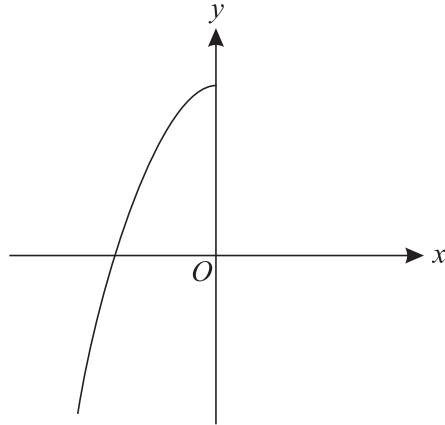

The diagram shows the graph of $y = f(x)$, where

$$f(x) = 2 - x^2, \quad x \leq 0.$$

(i) Evaluate $ff(-3)$. [3]

(ii) Find an expression for $f^{-1}(x)$. [3]

(iii) Sketch the graph of $y = f^{-1}(x)$. Indicate the coordinates of the points where the graph meets the axes. [3]

7 (a) Find the exact value of $\int_1^2 \frac{2}{(4x-1)^2} dx$. [4]

(b)

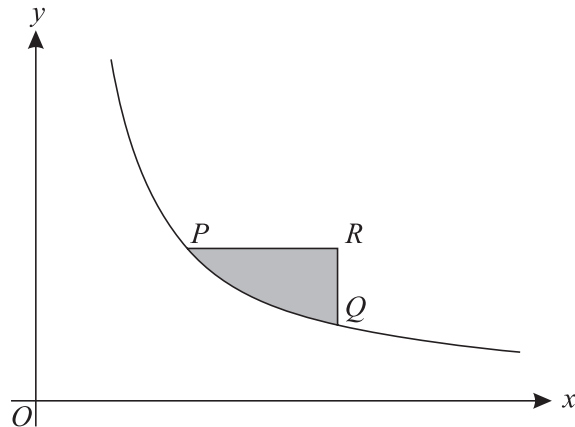

The diagram shows part of the curve $y = \frac{1}{x}$. The point P has coordinates $(a, \frac{1}{a})$ and the point Q has coordinates $(2a, \frac{1}{2a})$, where a is a positive constant. The point R is such that PR is parallel to the x -axis and QR is parallel to the y -axis. The region shaded in the diagram is bounded by the curve and by the lines PR and QR . Show that the area of this shaded region is $\ln(\frac{1}{2}e)$. [6]

- 8 (i) Express $5 \cos x + 12 \sin x$ in the form $R \cos(x - \alpha)$, where $R > 0$ and $0^\circ < \alpha < 90^\circ$. [3]
- (ii) Hence give details of a pair of transformations which transforms the curve $y = \cos x$ to the curve $y = 5 \cos x + 12 \sin x$. [3]
- (iii) Solve, for $0^\circ < x < 360^\circ$, the equation $5 \cos x + 12 \sin x = 2$, giving your answers correct to the nearest 0.1° . [5]

9

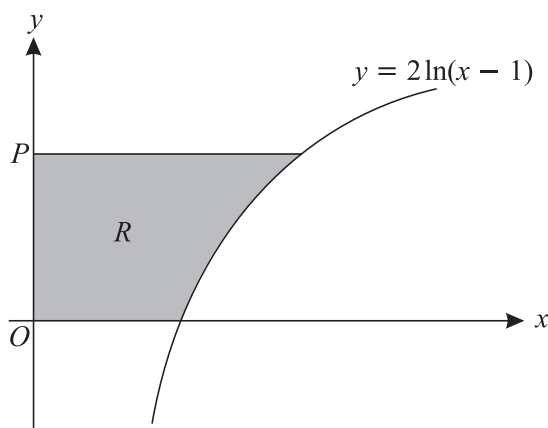

The diagram shows the curve with equation $y = 2 \ln(x - 1)$. The point P has coordinates $(0, p)$. The region R , shaded in the diagram, is bounded by the curve and the lines $x = 0$, $y = 0$ and $y = p$. The units on the axes are centimetres. The region R is rotated completely about the **y-axis** to form a solid.

- (i) Show that the volume, $V \text{ cm}^3$, of the solid is given by

$$V = \pi(e^p + 4e^{\frac{1}{2}p} + p - 5). \quad [8]$$

- (ii) It is given that the point P is moving in the positive direction along the y -axis at a constant rate of 0.2 cm min^{-1} . Find the rate at which the volume of the solid is increasing at the instant when $p = 4$, giving your answer correct to 2 significant figures. [5]

Jan 2007

- 1 Find the equation of the tangent to the curve $y = \frac{2x+1}{3x-1}$ at the point $(1, \frac{3}{2})$, giving your answer in the form $ax + by + c = 0$, where a , b and c are integers. [5]
- 2 It is given that θ is the acute angle such that $\sin \theta = \frac{12}{13}$. Find the exact value of
- (i) $\cot \theta$, [2]
- (ii) $\cos 2\theta$. [3]
- 3 (a) It is given that a and b are positive constants. By sketching graphs of
- $$y = x^5 \quad \text{and} \quad y = a - bx$$
- on the same diagram, show that the equation
- $$x^5 + bx - a = 0$$
- has exactly one real root. [3]
- (b) Use the iterative formula $x_{n+1} = \sqrt[5]{53 - 2x_n}$, with a suitable starting value, to find the real root of the equation $x^5 + 2x - 53 = 0$. Show the result of each iteration, and give the root correct to 3 decimal places. [4]
- 4 (i) Given that $x = (4t + 9)^{\frac{1}{2}}$ and $y = 6e^{\frac{1}{2}x+1}$, find expressions for $\frac{dx}{dt}$ and $\frac{dy}{dx}$. [4]
- (ii) Hence find the value of $\frac{dy}{dt}$ when $t = 4$, giving your answer correct to 3 significant figures. [3]
- 5 (i) Express $4 \cos \theta - \sin \theta$ in the form $R \cos(\theta + \alpha)$, where $R > 0$ and $0^\circ < \alpha < 90^\circ$. [3]
- (ii) Hence solve the equation $4 \cos \theta - \sin \theta = 2$, giving all solutions for which $-180^\circ < \theta < 180^\circ$. [5]

6

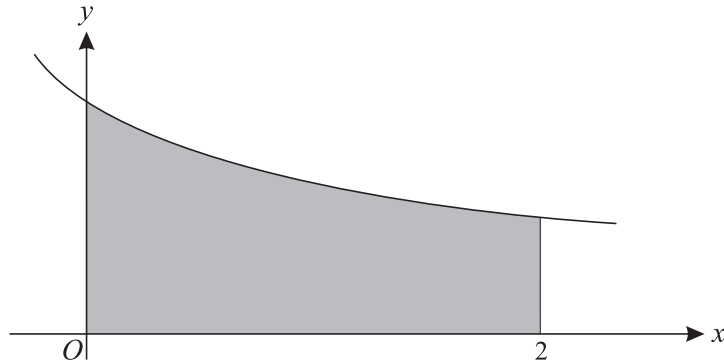

The diagram shows the curve with equation $y = \frac{1}{\sqrt{3x+2}}$. The shaded region is bounded by the curve and the lines $x = 0$, $x = 2$ and $y = 0$.

- (i) Find the exact area of the shaded region. [4]
- (ii) The shaded region is rotated completely about the x -axis. Find the exact volume of the solid formed, simplifying your answer. [5]

7 The curve $y = \ln x$ is transformed to the curve $y = \ln\left(\frac{1}{2}x - a\right)$ by means of a translation followed by a stretch. It is given that a is a positive constant.

- (i) Give full details of the translation and stretch involved. [2]
- (ii) Sketch the graph of $y = \ln\left(\frac{1}{2}x - a\right)$. [2]
- (iii) Sketch, on another diagram, the graph of $y = \left|\ln\left(\frac{1}{2}x - a\right)\right|$. [2]
- (iv) State, in terms of a , the set of values of x for which $\left|\ln\left(\frac{1}{2}x - a\right)\right| = -\ln\left(\frac{1}{2}x - a\right)$. [2]

[Questions 8 and 9 are printed overleaf.]

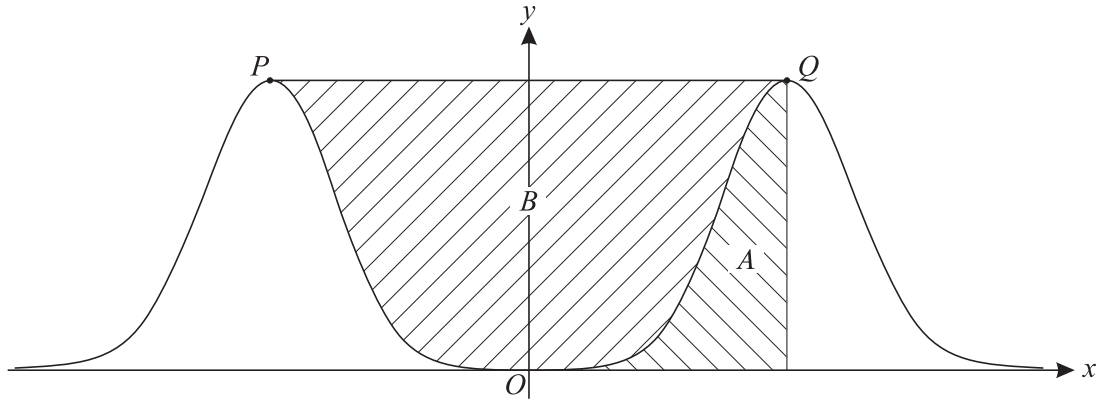

The diagram shows the curve with equation $y = x^8 e^{-x^2}$. The curve has maximum points at P and Q . The shaded region A is bounded by the curve, the line $y = 0$ and the line through Q parallel to the y -axis. The shaded region B is bounded by the curve and the line PQ .

(i) Show by differentiation that the x -coordinate of Q is 2. [5]

(ii) Use Simpson's rule with 4 strips to find an approximation to the area of region A . Give your answer correct to 3 decimal places. [4]

(iii) Deduce an approximation to the area of region B . [2]

9 Functions f and g are defined by

$$\begin{aligned} f(x) &= 2 \sin x & \text{for } -\frac{1}{2}\pi \leq x \leq \frac{1}{2}\pi, \\ g(x) &= 4 - 2x^2 & \text{for } x \in \mathbb{R}. \end{aligned}$$

(i) State the range of f and the range of g . [2]

(ii) Show that $gf(0.5) = 2.16$, correct to 3 significant figures, and explain why $fg(0.5)$ is not defined. [4]

(iii) Find the set of values of x for which $f^{-1}g(x)$ is not defined. [6]

June 2007

1 Differentiate each of the following with respect to x .

(i) $x^3(x+1)^5$ [2]

(ii) $\sqrt{3x^4+1}$ [3]

2 Solve the inequality $|4x-3| < |2x+1|$. [5]

3 The function f is defined for all non-negative values of x by

$$f(x) = 3 + \sqrt{x}.$$

(i) Evaluate $ff(169)$. [2]

(ii) Find an expression for $f^{-1}(x)$ in terms of x . [2]

(iii) On a single diagram sketch the graphs of $y = f(x)$ and $y = f^{-1}(x)$, indicating how the two graphs are related. [3]

4 The integral I is defined by

$$I = \int_0^{13} (2x+1)^{\frac{1}{3}} dx.$$

(i) Use integration to find the exact value of I . [4]

(ii) Use Simpson's rule with two strips to find an approximate value for I . Give your answer correct to 3 significant figures. [3]

5 A substance is decaying in such a way that its mass, m kg, at a time t years from now is given by the formula

$$m = 240e^{-0.04t}.$$

(i) Find the time taken for the substance to halve its mass. [3]

(ii) Find the value of t for which the mass is decreasing at a rate of 2.1 kg per year. [4]

6 (i) Given that $\int_0^a (6e^{2x} + x) dx = 42$, show that $a = \frac{1}{2} \ln(15 - \frac{1}{6}a^2)$. [5]

(ii) Use an iterative formula, based on the equation in part (i), to find the value of a correct to 3 decimal places. Use a starting value of 1 and show the result of each iteration. [4]

June 2007

- 7 (i) Sketch the graph of $y = \sec x$ for $0 \leq x \leq 2\pi$. [2]
- (ii) Solve the equation $\sec x = 3$ for $0 \leq x \leq 2\pi$, giving the roots correct to 3 significant figures. [3]
- (iii) Solve the equation $\sec \theta = 5 \operatorname{cosec} \theta$ for $0 \leq \theta \leq 2\pi$, giving the roots correct to 3 significant figures. [4]

8 (i) Given that $y = \frac{4 \ln x - 3}{4 \ln x + 3}$, show that $\frac{dy}{dx} = \frac{24}{x(4 \ln x + 3)^2}$. [3]

- (ii) Find the exact value of the gradient of the curve $y = \frac{4 \ln x - 3}{4 \ln x + 3}$ at the point where it crosses the x -axis. [4]

(iii)

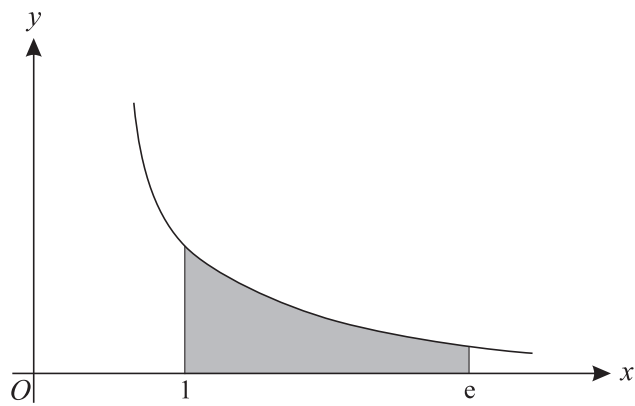

The diagram shows part of the curve with equation

$$y = \frac{2}{x^2(4 \ln x + 3)}$$

The region shaded in the diagram is bounded by the curve and the lines $x = 1$, $x = e$ and $y = 0$. Find the exact volume of the solid produced when this shaded region is rotated completely about the x -axis. [4]

- 9 (i) Prove the identity

$$\tan(\theta + 60^\circ) \tan(\theta - 60^\circ) \equiv \frac{\tan^2 \theta - 3}{1 - 3 \tan^2 \theta}. \quad [4]$$

- (ii) Solve, for $0^\circ < \theta < 180^\circ$, the equation

$$\tan(\theta + 60^\circ) \tan(\theta - 60^\circ) = 4 \sec^2 \theta - 3,$$

giving your answers correct to the nearest 0.1° . [5]

- (iii) Show that, for all values of the constant k , the equation

$$\tan(\theta + 60^\circ) \tan(\theta - 60^\circ) = k^2$$

has two roots in the interval $0^\circ < \theta < 180^\circ$. [3]

Jan 2008

- 1 Functions f and g are defined for all real values of x by

$$f(x) = x^3 + 4 \quad \text{and} \quad g(x) = 2x - 5.$$

Evaluate

(i) $fg(1)$, [2]

(ii) $f^{-1}(12)$. [3]

- 2 The sequence defined by

$$x_1 = 3, \quad x_{n+1} = \sqrt[3]{31 - \frac{5}{2}x_n}$$

converges to the number α .

(i) Find the value of α correct to 3 decimal places, showing the result of each iteration. [3]

(ii) Find an equation of the form $ax^3 + bx + c = 0$, where a , b and c are integers, which has α as a root. [3]

3 (a) Solve, for $0^\circ < \alpha < 180^\circ$, the equation $\sec \frac{1}{2}\alpha = 4$. [3]

(b) Solve, for $0^\circ < \beta < 180^\circ$, the equation $\tan \beta = 7 \cot \beta$. [4]

- 4 Earth is being added to a pile so that, when the height of the pile is h metres, its volume is V cubic metres, where

$$V = (h^6 + 16)^{\frac{1}{2}} - 4.$$

(i) Find the value of $\frac{dV}{dh}$ when $h = 2$. [3]

(ii) The volume of the pile is increasing at a constant rate of 8 cubic metres per hour. Find the rate, in metres per hour, at which the height of the pile is increasing at the instant when $h = 2$. Give your answer correct to 2 significant figures. [3]

5 (a) Find $\int (3x + 7)^9 dx$. [3]

(b)

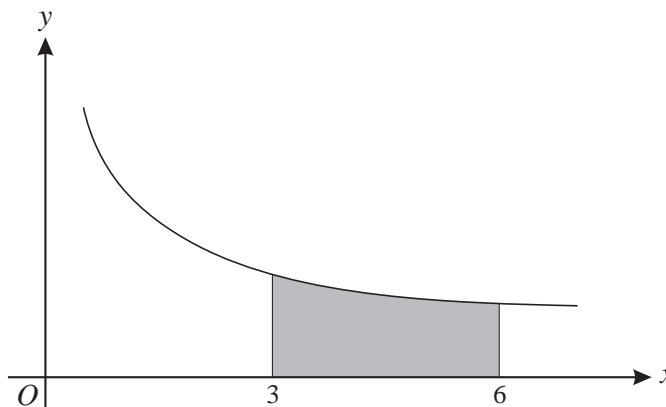

The diagram shows the curve $y = \frac{1}{2\sqrt{x}}$. The shaded region is bounded by the curve and the lines $x = 3$, $x = 6$ and $y = 0$. The shaded region is rotated completely about the x -axis. Find the exact volume of the solid produced, simplifying your answer. [5]

6

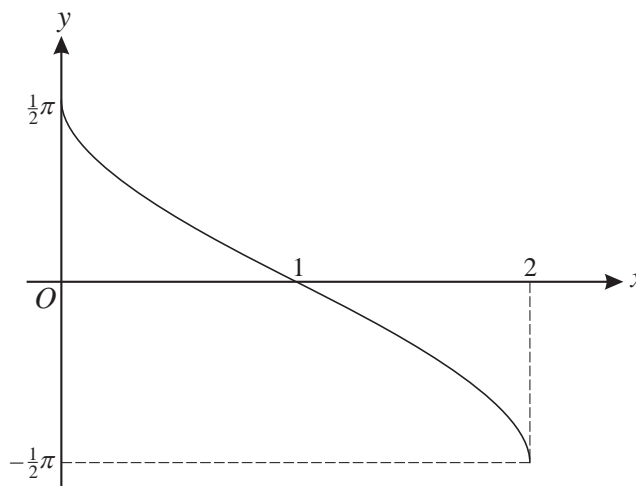

The diagram shows the graph of $y = -\sin^{-1}(x - 1)$.

- (i) Give details of the pair of geometrical transformations which transforms the graph of $y = -\sin^{-1}(x - 1)$ to the graph of $y = \sin^{-1} x$. [3]
- (ii) Sketch the graph of $y = |-\sin^{-1}(x - 1)|$. [2]
- (iii) Find the exact solutions of the equation $|-\sin^{-1}(x - 1)| = \frac{1}{3}\pi$. [3]

Jan 2008

7 A curve has equation $y = \frac{xe^{2x}}{x+k}$, where k is a non-zero constant.

(i) Differentiate xe^{2x} , and show that $\frac{dy}{dx} = \frac{e^{2x}(2x^2 + 2kx + k)}{(x+k)^2}$. [5]

(ii) Given that the curve has exactly one stationary point, find the value of k , and determine the exact coordinates of the stationary point. [5]

8 The definite integral I is defined by

$$I = \int_0^6 2^x dx.$$

(i) Use Simpson's rule with 6 strips to find an approximate value of I . [4]

(ii) By first writing 2^x in the form e^{kx} , where the constant k is to be determined, find the exact value of I . [4]

(iii) Use the answers to parts (i) and (ii) to deduce that $\ln 2 \approx \frac{9}{13}$. [2]

9 (i) Use the identity for $\cos(A+B)$ to prove that

$$4 \cos(\theta + 60^\circ) \cos(\theta + 30^\circ) \equiv \sqrt{3} - 2 \sin 2\theta. \quad [4]$$

(ii) Hence find the exact value of $4 \cos 82.5^\circ \cos 52.5^\circ$. [2]

(iii) Solve, for $0^\circ < \theta < 90^\circ$, the equation $4 \cos(\theta + 60^\circ) \cos(\theta + 30^\circ) = 1$. [3]

(iv) Given that there are no values of θ which satisfy the equation

$$4 \cos(\theta + 60^\circ) \cos(\theta + 30^\circ) = k,$$

determine the set of values of the constant k . [3]

Permission to reproduce items where third-party owned material protected by copyright is included has been sought and cleared where possible. Every reasonable effort has been made by the publisher (OCR) to trace copyright holders, but if any items requiring clearance have unwittingly been included, the publisher will be pleased to make amends at the earliest possible opportunity.

OCR is part of the Cambridge Assessment Group. Cambridge Assessment is the brand name of University of Cambridge Local Examinations Syndicate (UCLES), which is itself a department of the University of Cambridge.

- 1 Find the exact solutions of the equation $|4x - 5| = |3x - 5|$. [4]

2

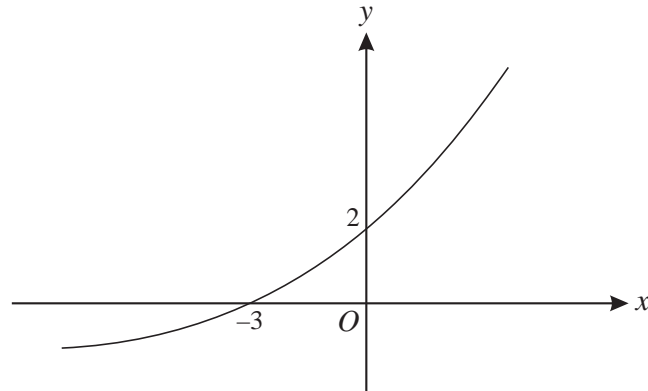

The diagram shows the graph of $y = f(x)$. It is given that $f(-3) = 0$ and $f(0) = 2$. Sketch, on separate diagrams, the following graphs, indicating in each case the coordinates of the points where the graph crosses the axes:

(i) $y = f^{-1}(x)$, [2]

(ii) $y = -2f(x)$. [3]

- 3 Find, in the form $y = mx + c$, the equation of the tangent to the curve

$$y = x^2 \ln x$$

at the point with x -coordinate e . [6]

- 4 The gradient of the curve $y = (2x^2 + 9)^{\frac{5}{2}}$ at the point P is 100.

(i) Show that the x -coordinate of P satisfies the equation $x = 10(2x^2 + 9)^{-\frac{3}{2}}$. [3]

(ii) Show by calculation that the x -coordinate of P lies between 0.3 and 0.4. [3]

(iii) Use an iterative formula, based on the equation in part (i), to find the x -coordinate of P correct to 4 decimal places. You should show the result of each iteration. [3]

- 5 (a) Express $\tan 2\alpha$ in terms of $\tan \alpha$ and hence solve, for $0^\circ < \alpha < 180^\circ$, the equation

$$\tan 2\alpha \tan \alpha = 8. \quad [6]$$

(b) Given that β is the acute angle such that $\sin \beta = \frac{6}{7}$, find the exact value of

(i) $\operatorname{cosec} \beta$, [1]

(ii) $\cot^2 \beta$. [2]

6

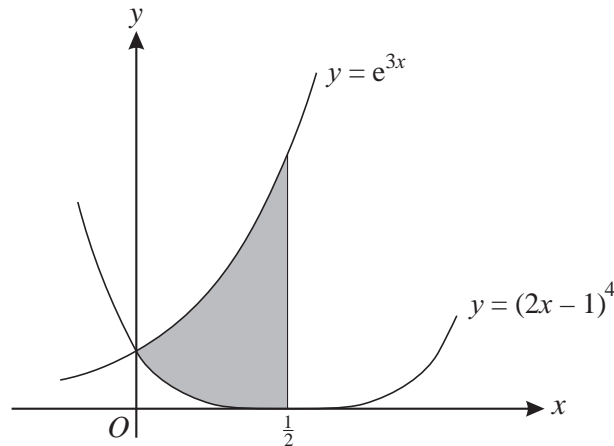

The diagram shows the curves $y = e^{3x}$ and $y = (2x - 1)^4$. The shaded region is bounded by the two curves and the line $x = \frac{1}{2}$. The shaded region is rotated completely about the x -axis. Find the exact volume of the solid produced. [9]

- 7 It is claimed that the number of plants of a certain species in a particular locality is doubling every 9 years. The number of plants now is 42. The number of plants is treated as a continuous variable and is denoted by N . The number of years from now is denoted by t .

(i) Two equivalent expressions giving N in terms of t are

$$N = A \times 2^{kt} \quad \text{and} \quad N = Ae^{mt}.$$

Determine the value of each of the constants A , k and m . [4]

(ii) Find the value of t for which $N = 100$, giving your answer correct to 3 significant figures. [2]

(iii) Find the rate at which the number of plants will be increasing at a time 35 years from now. [3]

- 8 The expression $T(\theta)$ is defined for θ in degrees by

$$T(\theta) = 3 \cos(\theta - 60^\circ) + 2 \cos(\theta + 60^\circ).$$

(i) Express $T(\theta)$ in the form $A \sin \theta + B \cos \theta$, giving the exact values of the constants A and B . [3]

(ii) Hence express $T(\theta)$ in the form $R \sin(\theta + \alpha)$, where $R > 0$ and $0^\circ < \alpha < 90^\circ$. [3]

(iii) Find the smallest positive value of θ such that $T(\theta) + 1 = 0$. [4]

[Question 9 is printed overleaf.]

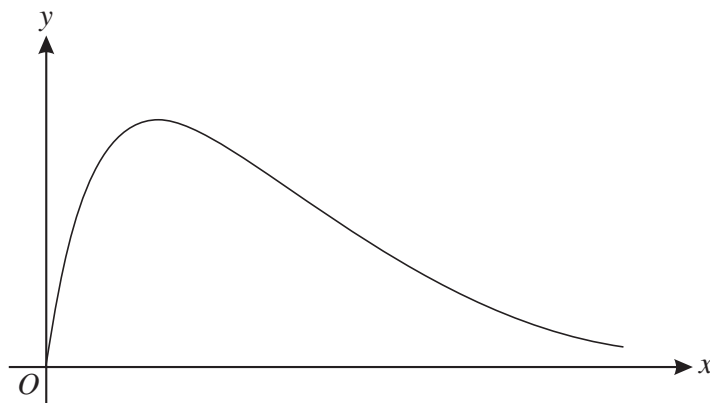

The function f is defined for the domain $x \geq 0$ by

$$f(x) = \frac{15x}{x^2 + 5}.$$

The diagram shows the curve with equation $y = f(x)$.

(i) Find the range of f . [6]

(ii) The function g is defined for the domain $x \geq k$ by

$$g(x) = \frac{15x}{x^2 + 5}.$$

Given that g is a one-one function, state the least possible value of k . [1]

(iii) Show that there is no point on the curve $y = g(x)$ at which the gradient is -1 . [4]

Jan 2009**1** Find

(i) $\int 8e^{-2x} dx,$

(ii) $\int (4x + 5)^6 dx.$

[5]**2** (i) Use Simpson's rule with four strips to find an approximation to

$$\int_4^{12} \ln x dx,$$

giving your answer correct to 2 decimal places.

[4]

(ii) Deduce an approximation to $\int_4^{12} \ln(x^{10}) dx.$

[1]**3** (i) Express $2 \tan^2 \theta - \frac{1}{\cos \theta}$ in terms of $\sec \theta.$ **[3]**(ii) Hence solve, for $0^\circ < \theta < 360^\circ,$ the equation

$$2 \tan^2 \theta - \frac{1}{\cos \theta} = 4.$$

[4]**4** For each of the following curves, find $\frac{dy}{dx}$ and determine the exact x -coordinate of the stationary point:

(i) $y = (4x^2 + 1)^5,$

[3]

(ii) $y = \frac{x^2}{\ln x}.$

[4]**5** The mass, M grams, of a certain substance is increasing exponentially so that, at time t hours, the mass is given by

$$M = 40e^{kt},$$

where k is a constant. The following table shows certain values of t and $M.$

t	0	21	63
M		80	

(i) In either order,

(a) find the values missing from the table,

[3](b) determine the value of $k.$ **[2]**(ii) Find the rate at which the mass is increasing when $t = 21.$ **[3]**

Jan 2009

6

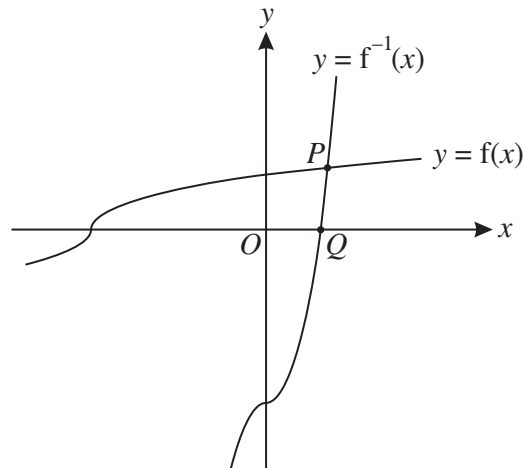

The function f is defined for all real values of x by

$$f(x) = \sqrt[3]{\frac{1}{2}x + 2}.$$

The graphs of $y = f(x)$ and $y = f^{-1}(x)$ meet at the point P , and the graph of $y = f^{-1}(x)$ meets the x -axis at Q (see diagram).

- (i) Find an expression for $f^{-1}(x)$ and determine the x -coordinate of the point Q . [3]
- (ii) State how the graphs of $y = f(x)$ and $y = f^{-1}(x)$ are related geometrically, and hence show that the x -coordinate of the point P is the root of the equation

$$x = \sqrt[3]{\frac{1}{2}x + 2}. \quad [2]$$

- (iii) Use an iterative process, based on the equation $x = \sqrt[3]{\frac{1}{2}x + 2}$, to find the x -coordinate of P , giving your answer correct to 2 decimal places. [4]

7

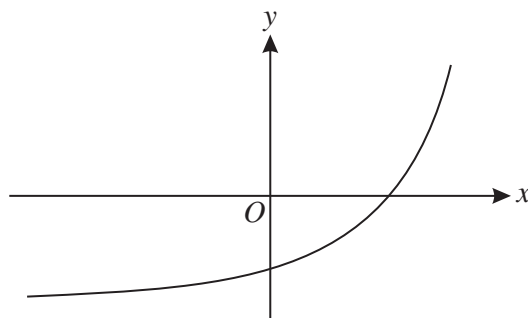

The diagram shows the curve $y = e^{kx} - a$, where k and a are constants.

- (i) Give details of the pair of transformations which transforms the curve $y = e^x$ to the curve $y = e^{kx} - a$. [3]
- (ii) Sketch the curve $y = |e^{kx} - a|$. [2]
- (iii) Given that the curve $y = |e^{kx} - a|$ passes through the points $(0, 13)$ and $(\ln 3, 13)$, find the values of k and a . [4]

Jan 2009

8

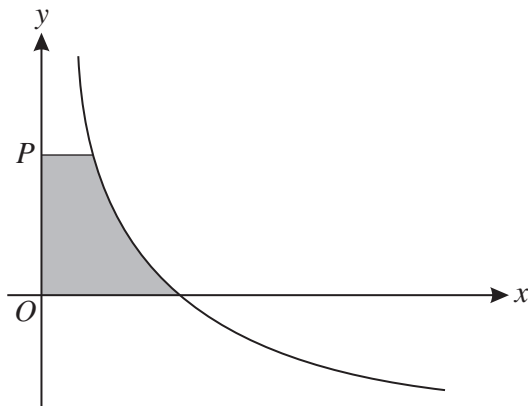

The diagram shows the curve with equation

$$y = \frac{6}{\sqrt{x}} - 3.$$

The point P has coordinates $(0, p)$. The shaded region is bounded by the curve and the lines $x = 0$, $y = 0$ and $y = p$. The shaded region is rotated completely about the y -axis to form a solid of volume V .

(i) Show that $V = 16\pi \left(1 - \frac{27}{(p+3)^3} \right)$. [6]

(ii) It is given that P is moving along the y -axis in such a way that, at time t , the variables p and t are related by

$$\frac{dp}{dt} = \frac{1}{3}p + 1.$$

Find the value of $\frac{dV}{dt}$ at the instant when $p = 9$. [4]

9 (i) By first expanding $\cos(2\theta + \theta)$, prove that

$$\cos 3\theta \equiv 4 \cos^3 \theta - 3 \cos \theta. \quad [4]$$

(ii) Hence prove that

$$\cos 6\theta \equiv 32 \cos^6 \theta - 48 \cos^4 \theta + 18 \cos^2 \theta - 1. \quad [3]$$

(iii) Show that the only solutions of the equation

$$1 + \cos 6\theta = 18 \cos^2 \theta$$

are odd multiples of 90° . [5]

1

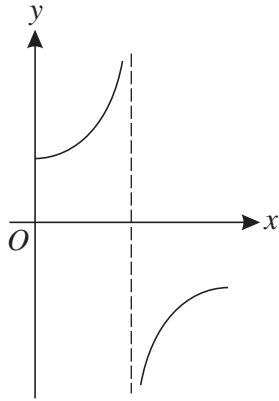

Fig. 1

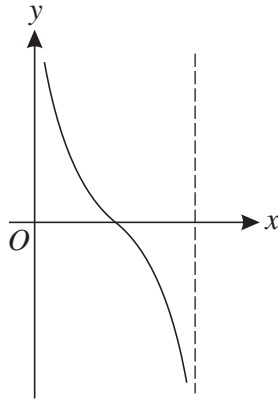

Fig. 2

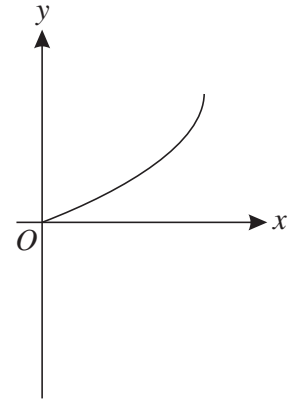

Fig. 3

Each diagram above shows part of a curve, the equation of which is one of the following:

$$y = \sin^{-1} x, \quad y = \cos^{-1} x, \quad y = \tan^{-1} x, \quad y = \sec x, \quad y = \operatorname{cosec} x, \quad y = \cot x.$$

State which equation corresponds to

- (i) Fig. 1, [1]
- (ii) Fig. 2, [1]
- (iii) Fig. 3. [1]

2

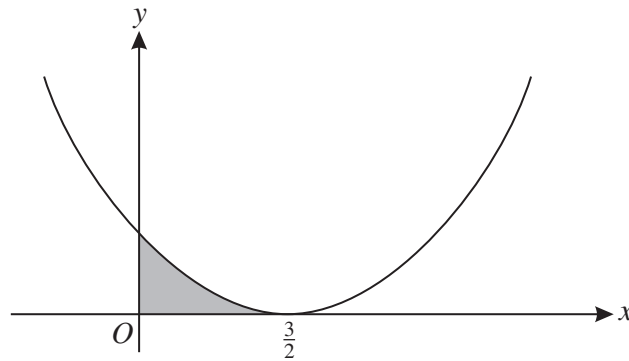

The diagram shows the curve with equation $y = (2x - 3)^2$. The shaded region is bounded by the curve and the lines $x = 0$ and $y = 0$. Find the exact volume obtained when the shaded region is rotated completely about the x -axis. [5]

3 The angles α and β are such that

$$\tan \alpha = m + 2 \quad \text{and} \quad \tan \beta = m,$$

where m is a constant.

- (i) Given that $\sec^2 \alpha - \sec^2 \beta = 16$, find the value of m . [3]
- (ii) Hence find the exact value of $\tan(\alpha + \beta)$. [3]

4 It is given that $\int_a^{3a} (e^{3x} + e^x) dx = 100$, where a is a positive constant.

(i) Show that $a = \frac{1}{9} \ln(300 + 3e^a - 2e^{3a})$. [5]

(ii) Use an iterative process, based on the equation in part (i), to find the value of a correct to 4 decimal places. Use a starting value of 0.6 and show the result of each step of the process. [4]

5 The functions f and g are defined for all real values of x by

$$f(x) = 3x - 2 \quad \text{and} \quad g(x) = 3x + 7.$$

Find the exact coordinates of the point at which

(i) the graph of $y = fg(x)$ meets the x -axis, [3]

(ii) the graph of $y = g(x)$ meets the graph of $y = g^{-1}(x)$, [3]

(iii) the graph of $y = |f(x)|$ meets the graph of $y = |g(x)|$. [4]

6

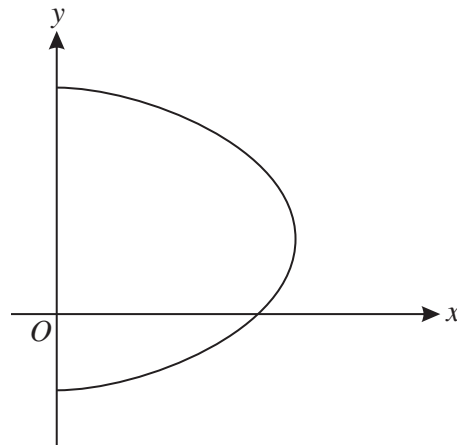

The diagram shows the curve with equation $x = (37 + 10y - 2y^2)^{\frac{1}{2}}$.

(i) Find an expression for $\frac{dx}{dy}$ in terms of y . [2]

(ii) Hence find the equation of the tangent to the curve at the point $(7, 3)$, giving your answer in the form $y = mx + c$. [5]

7 (i) Express $8 \sin \theta - 6 \cos \theta$ in the form $R \sin(\theta - \alpha)$, where $R > 0$ and $0^\circ < \alpha < 90^\circ$. [3]

(ii) Hence

(a) solve, for $0^\circ < \theta < 360^\circ$, the equation $8 \sin \theta - 6 \cos \theta = 9$, [4]

(b) find the greatest possible value of

$$32 \sin x - 24 \cos x - (16 \sin y - 12 \cos y)$$

as the angles x and y vary. [3]

8

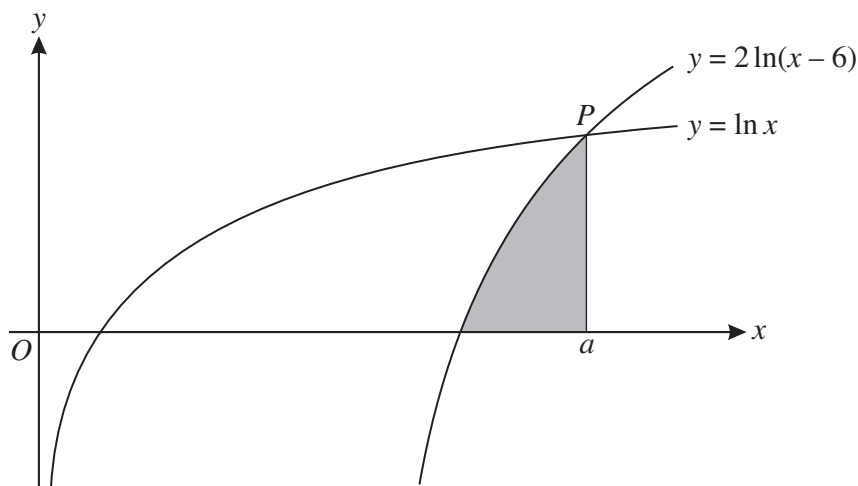

The diagram shows the curves $y = \ln x$ and $y = 2 \ln(x - 6)$. The curves meet at the point P which has x -coordinate a . The shaded region is bounded by the curve $y = 2 \ln(x - 6)$ and the lines $x = a$ and $y = 0$.

(i) Give details of the pair of transformations which transforms the curve $y = \ln x$ to the curve $y = 2 \ln(x - 6)$. [3]

(ii) Solve an equation to find the value of a . [4]

(iii) Use Simpson's rule with two strips to find an approximation to the area of the shaded region. [3]

9 (a) Show that, for all non-zero values of the constant k , the curve

$$y = \frac{kx^2 - 1}{kx^2 + 1}$$

has exactly one stationary point. [5]

(b) Show that, for all non-zero values of the constant m , the curve

$$y = e^{mx}(x^2 + mx)$$

has exactly two stationary points. [7]



Copyright Information

OCR is committed to seeking permission to reproduce all third-party content that it uses in its assessment materials. OCR has attempted to identify and contact all copyright holders whose work is used in this paper. To avoid the issue of disclosure of answer-related information to candidates, all copyright acknowledgements are reproduced in the OCR Copyright Acknowledgements Booklet. This is produced for each series of examinations, is given to all schools that receive assessment material and is freely available to download from our public website (www.ocr.org.uk) after the live examination series.

If OCR has unwittingly failed to correctly acknowledge or clear any third-party content in this assessment material, OCR will be happy to correct its mistake at the earliest possible opportunity.

For queries or further information please contact the Copyright Team, First Floor, 9 Hills Road, Cambridge CB2 1PB.

OCR is part of the Cambridge Assessment Group; Cambridge Assessment is the brand name of University of Cambridge Local Examinations Syndicate (UCLES), which is itself a department of the University of Cambridge.

1 Find $\int \frac{10}{(2x-7)^2} dx$. [3]

2 The angle θ is such that $0^\circ < \theta < 90^\circ$.

(i) Given that θ satisfies the equation $6 \sin 2\theta = 5 \cos \theta$, find the exact value of $\sin \theta$. [3]

(ii) Given instead that θ satisfies the equation $8 \cos \theta \operatorname{cosec}^2 \theta = 3$, find the exact value of $\cos \theta$. [5]

3 (i) Find, in simplified form, the exact value of $\int_{10}^{20} \frac{60}{x} dx$. [2]

(ii) Use Simpson's rule with two strips to find an approximation to $\int_{10}^{20} \frac{60}{x} dx$. [3]

(iii) Use your answers to parts (i) and (ii) to show that $\ln 2 \approx \frac{25}{36}$. [2]

4

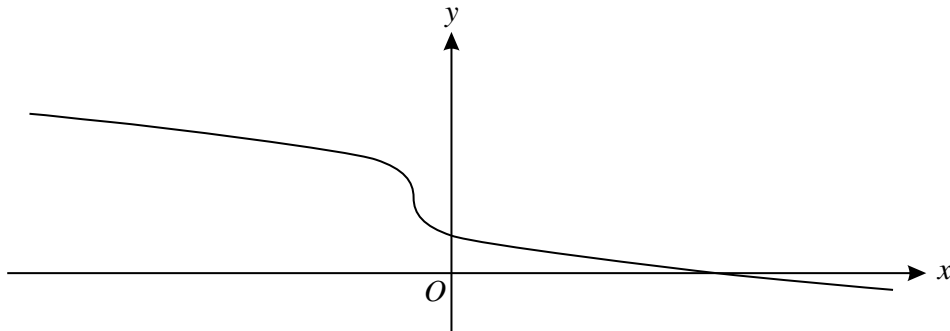

The function f is defined for all real values of x by

$$f(x) = 2 - \sqrt[3]{x+1}.$$

The diagram shows the graph of $y = f(x)$.

(i) Evaluate $ff(-126)$. [2]

(ii) Find the set of values of x for which $f(x) = |f(x)|$. [2]

(iii) Find an expression for $f^{-1}(x)$. [3]

(iv) State how the graphs of $y = f(x)$ and $y = f^{-1}(x)$ are related geometrically. [1]

5 The equation of a curve is $y = (x^2 + 1)^8$.

(i) Find an expression for $\frac{dy}{dx}$ and hence show that the only stationary point on the curve is the point for which $x = 0$. [4]

(ii) Find an expression for $\frac{d^2y}{dx^2}$ and hence find the value of $\frac{d^2y}{dx^2}$ at the stationary point. [5]

6 Given that

$$\int_0^{\ln 4} (ke^{3x} + (k-2)e^{-\frac{1}{2}x}) dx = 185,$$

find the value of the constant k .

[7]

7 (a) Leaking oil is forming a circular patch on the surface of the sea. The area of the patch is increasing at a rate of 250 square metres per hour. Find the rate at which the radius of the patch is increasing at the instant when the area of the patch is 1900 square metres. Give your answer correct to 2 significant figures. [4]

(b) The mass of a substance is decreasing exponentially. Its mass now is 150 grams and its mass, m grams, at a time t years from now is given by

$$m = 150e^{-kt},$$

where k is a positive constant. Find, in terms of k , the number of years from now at which the mass will be decreasing at a rate of 3 grams per year. [3]

8 (i) The curve $y = \sqrt{x}$ can be transformed to the curve $y = \sqrt{2x+3}$ by means of a stretch parallel to the y -axis followed by a translation. State the scale factor of the stretch and give details of the translation. [3]

(ii) It is given that N is a positive integer. By sketching on a single diagram the graphs of $y = \sqrt{2x+3}$ and $y = \frac{N}{x^3}$, show that the equation

$$\sqrt{2x+3} = \frac{N}{x^3}$$

has exactly one real root.

[3]

(iii) A sequence x_1, x_2, x_3, \dots has the property that

$$x_{n+1} = N^{\frac{1}{3}}(2x_n + 3)^{-\frac{1}{6}}.$$

For certain values of x_1 and N , it is given that the sequence converges to the root of the equation

$$\sqrt{2x+3} = \frac{N}{x^3}.$$

(a) Find the value of the integer N for which the sequence converges to the value 1.9037 (correct to 4 decimal places). [2]

(b) Find the value of the integer N for which, correct to 4 decimal places, $x_3 = 2.6022$ and $x_4 = 2.6282$. [3]

[Question 9 is printed overleaf.]

Jan 2010

- 9 The value of $\tan 10^\circ$ is denoted by p . Find, in terms of p , the value of
- (i) $\tan 55^\circ$, [3]
 - (ii) $\tan 5^\circ$, [4]
 - (iii) $\tan \theta$, where θ satisfies the equation $3 \sin(\theta + 10^\circ) = 7 \cos(\theta - 10^\circ)$. [5]

**Copyright Information**

OCR is committed to seeking permission to reproduce all third-party content that it uses in its assessment materials. OCR has attempted to identify and contact all copyright holders whose work is used in this paper. To avoid the issue of disclosure of answer-related information to candidates, all copyright acknowledgements are reproduced in the OCR Copyright Acknowledgements Booklet. This is produced for each series of examinations, is given to all schools that receive assessment material and is freely available to download from our public website (www.ocr.org.uk) after the live examination series.

If OCR has unwittingly failed to correctly acknowledge or clear any third-party content in this assessment material, OCR will be happy to correct its mistake at the earliest possible opportunity. For queries or further information please contact the Copyright Team, First Floor, 9 Hills Road, Cambridge CB2 1GE.

OCR is part of the Cambridge Assessment Group; Cambridge Assessment is the brand name of University of Cambridge Local Examinations Syndicate (UCLES), which is itself a department of the University of Cambridge.

1 Find $\frac{dy}{dx}$ in each of the following cases:

(i) $y = x^3 e^{2x}$, [2]

(ii) $y = \ln(3 + 2x^2)$, [2]

(iii) $y = \frac{x}{2x + 1}$. [2]

2 The transformations R, S and T are defined as follows.

R : reflection in the x -axis

S : stretch in the x -direction with scale factor 3

T : translation in the positive x -direction by 4 units

(i) The curve $y = \ln x$ is transformed by R followed by T. Find the equation of the resulting curve. [2]

(ii) Find, in terms of S and T, a sequence of transformations that transforms the curve $y = x^3$ to the curve $y = (\frac{1}{9}x - 4)^3$. You should make clear the order of the transformations. [2]

3 (i) Express the equation $\operatorname{cosec} \theta(3 \cos 2\theta + 7) + 11 = 0$ in the form $a \sin^2 \theta + b \sin \theta + c = 0$, where a , b and c are constants. [3]

(ii) Hence solve, for $-180^\circ < \theta < 180^\circ$, the equation $\operatorname{cosec} \theta(3 \cos 2\theta + 7) + 11 = 0$. [3]

4

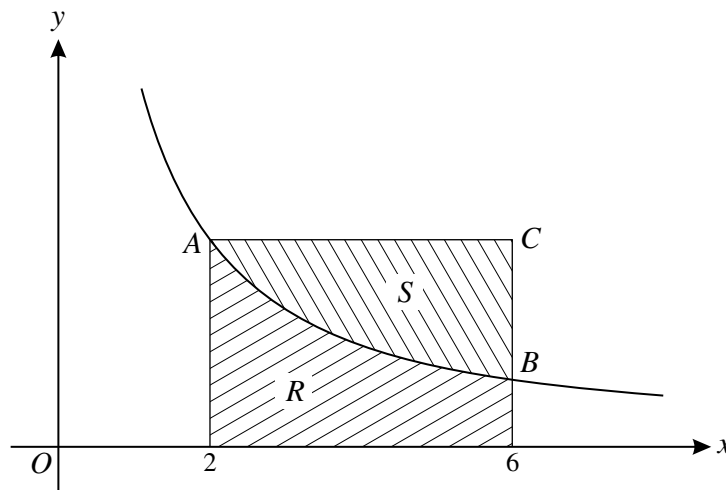

The diagram shows part of the curve $y = \frac{k}{x}$, where k is a positive constant. The points A and B on the curve have x -coordinates 2 and 6 respectively. Lines through A and B parallel to the axes as shown meet at the point C . The region R is bounded by the curve and the lines $x = 2$, $x = 6$ and $y = 0$. The region S is bounded by the curve and the lines AC and BC . It is given that the area of the region R is $\ln 81$.

(i) Show that $k = 4$. [3]

(ii) Find the exact volume of the solid produced when the region S is rotated completely about the x -axis. [4]

- 5 (i) Solve the inequality $|2x + 1| \leq |x - 3|$. [5]
- (ii) Given that x satisfies the inequality $|2x + 1| \leq |x - 3|$, find the greatest possible value of $|x + 2|$. [2]

- 6 (i) Show by calculation that the equation

$$\tan^2 x - x - 2 = 0,$$

where x is measured in radians, has a root between 1.0 and 1.1. [3]

- (ii) Use the iteration formula $x_{n+1} = \tan^{-1} \sqrt{2 + x_n}$ with a suitable starting value to find this root correct to 5 decimal places. You should show the outcome of each step of the process. [4]

- (iii) Deduce a root of the equation

$$\sec^2 2x - 2x - 3 = 0. \quad [3]$$

7

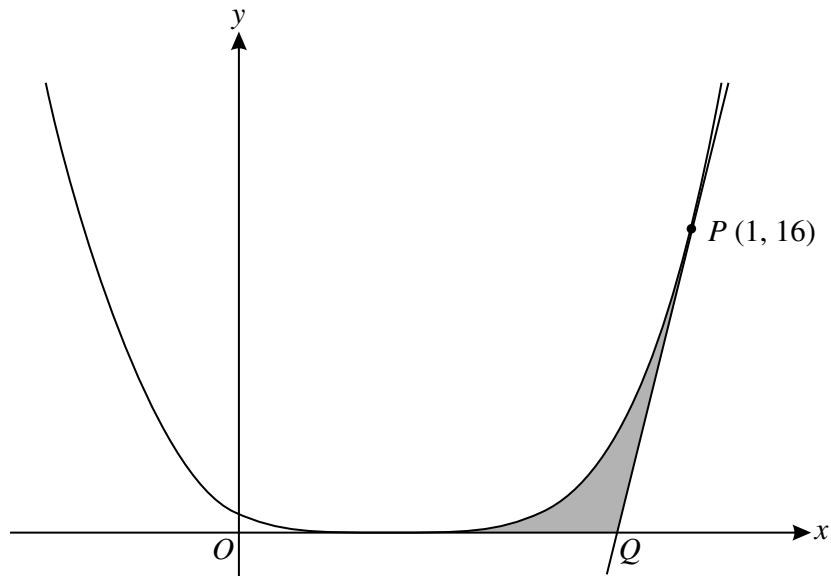

The diagram shows the curve with equation $y = (3x - 1)^4$. The point P on the curve has coordinates $(1, 16)$ and the tangent to the curve at P meets the x -axis at the point Q . The shaded region is bounded by PQ , the x -axis and that part of the curve for which $\frac{1}{3} \leq x \leq 1$. Find the exact area of this shaded region. [10]

- 8 (i) Express $3 \cos x + 3 \sin x$ in the form $R \cos(x - \alpha)$, where $R > 0$ and $0 < \alpha < \frac{1}{2}\pi$. [3]
- (ii) The expression $T(x)$ is defined by $T(x) = \frac{8}{3 \cos x + 3 \sin x}$.
- (a) Determine a value of x for which $T(x)$ is not defined. [2]
- (b) Find the smallest positive value of x satisfying $T(3x) = \frac{8}{9}\sqrt{6}$, giving your answer in an exact form. [4]

[Question 9 is printed overleaf.]

June 2010

9 The functions f and g are defined for all real values of x by

$$f(x) = 4x^2 - 12x \quad \text{and} \quad g(x) = ax + b,$$

where a and b are non-zero constants.

- (i) Find the range of f . [3]
- (ii) Explain why the function f has no inverse. [2]
- (iii) Given that $g^{-1}(x) = g(x)$ for all values of x , show that $a = -1$. [4]
- (iv) Given further that $gf(x) < 5$ for all values of x , find the set of possible values of b . [4]



Copyright Information

OCR is committed to seeking permission to reproduce all third-party content that it uses in its assessment materials. OCR has attempted to identify and contact all copyright holders whose work is used in this paper. To avoid the issue of disclosure of answer-related information to candidates, all copyright acknowledgements are reproduced in the OCR Copyright Acknowledgements Booklet. This is produced for each series of examinations, is given to all schools that receive assessment material and is freely available to download from our public website (www.ocr.org.uk) after the live examination series.

If OCR has unwittingly failed to correctly acknowledge or clear any third-party content in this assessment material, OCR will be happy to correct its mistake at the earliest possible opportunity. For queries or further information please contact the Copyright Team, First Floor, 9 Hills Road, Cambridge CB2 1GE.

OCR is part of the Cambridge Assessment Group; Cambridge Assessment is the brand name of University of Cambridge Local Examinations Syndicate (UCLES), which is itself a department of the University of Cambridge.

- 1 Solve the equation $|3x + 4a| = 5a$, where a is a positive constant. [3]

2

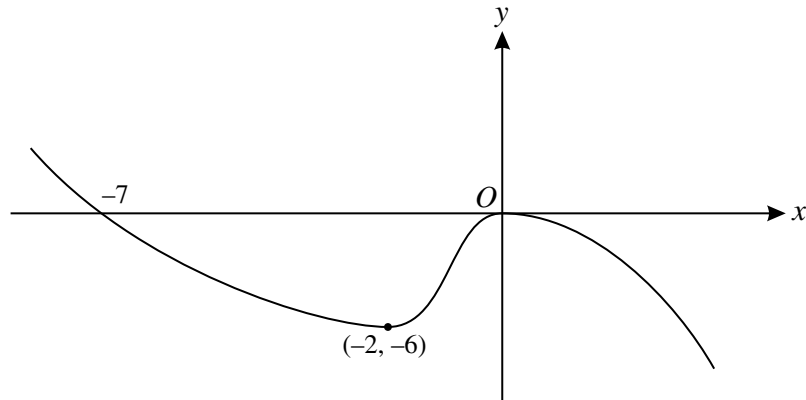

The diagram shows the curve with equation $y = f(x)$. It is given that $f(-7) = 0$ and that there are stationary points at $(-2, -6)$ and $(0, 0)$. Sketch the curve with equation $y = -4f(x + 3)$, indicating the coordinates of the stationary points. [4]

- 3 A giant spherical balloon is being inflated in a theme park. The radius of the balloon is increasing at a rate of 12 cm per hour. Find the rate at which the surface area of the balloon is increasing at the instant when the radius is 150 cm. Give your answer in cm^2 per hour correct to 2 significant figures. [3]

[Surface area of sphere = $4\pi r^2$.]

- 4 (i) Express $24 \sin \theta + 7 \cos \theta$ in the form $R \sin(\theta + \alpha)$, where $R > 0$ and $0^\circ < \alpha < 90^\circ$. [3]

- (ii) Hence solve the equation $24 \sin \theta + 7 \cos \theta = 12$ for $0^\circ < \theta < 360^\circ$. [4]

5

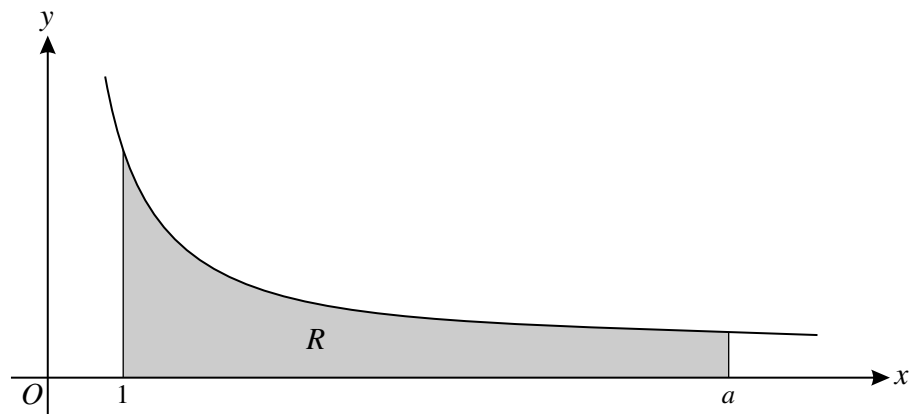

The diagram shows the curve with equation $y = \frac{6}{\sqrt{3x-2}}$. The region R , shaded in the diagram, is bounded by the curve and the lines $x = 1$, $x = a$ and $y = 0$, where a is a constant greater than 1. It is given that the area of R is 16 square units. Find the value of a and hence find the exact volume of the solid formed when R is rotated completely about the x -axis. [9]

Jan 2011

- 6 The curve with equation $y = \frac{3x+4}{x^3-4x^2+2}$ has a stationary point at P . It is given that P is close to the point with coordinates $(2.4, -1.6)$.

(i) Find an expression for $\frac{dy}{dx}$ and show that the x -coordinate of P satisfies the equation

$$x = \sqrt[3]{\frac{16}{3}x + 1}. \quad [4]$$

(ii) By first using an iterative process based on the equation in part (i), find the coordinates of P , giving each coordinate correct to 3 decimal places. [5]

- 7 The function f is defined for $x > 0$ by $f(x) = \ln x$ and the function g is defined for all real values of x by $g(x) = x^2 + 8$.

(i) Find the exact, positive value of x which satisfies the equation $fg(x) = 8$. [3]

(ii) State which one of f and g has an inverse and define that inverse function. [3]

(iii) Find the exact value of the gradient of the curve $y = gf(x)$ at the point with x -coordinate e^3 . [3]

(iv) Use Simpson's rule with four strips to find an approximate value of

$$\int_{-4}^4 fg(x) dx,$$

giving your answer correct to 3 significant figures. [3]

- 8 (a) (i) Sketch the graph of $y = \operatorname{cosec} x$ for $0 < x < 4\pi$. [3]

(ii) It is given that $\operatorname{cosec} \alpha = \operatorname{cosec} \beta$, where $\frac{1}{2}\pi < \alpha < \pi$ and $2\pi < \beta < \frac{5}{2}\pi$. By using your sketch, or otherwise, express β in terms of α . [2]

(b) (i) Write down the identity giving $\tan 2\theta$ in terms of $\tan \theta$. [1]

(ii) Given that $\cot \phi = 4$, find the exact value of $\tan \phi \cot 2\phi \tan 4\phi$, showing all your working. [6]

[Question 9 is printed overleaf.]

Jan 2011

- 9 (i) The function f is defined for all real values of x by

$$f(x) = e^{2x} - 3e^{-2x}.$$

- (a) Show that $f'(x) > 0$ for all x . [3]
- (b) Show that the set of values of x for which $f''(x) > 0$ is the same as the set of values of x for which $f(x) > 0$, and state what this set of values is. [5]

(ii)

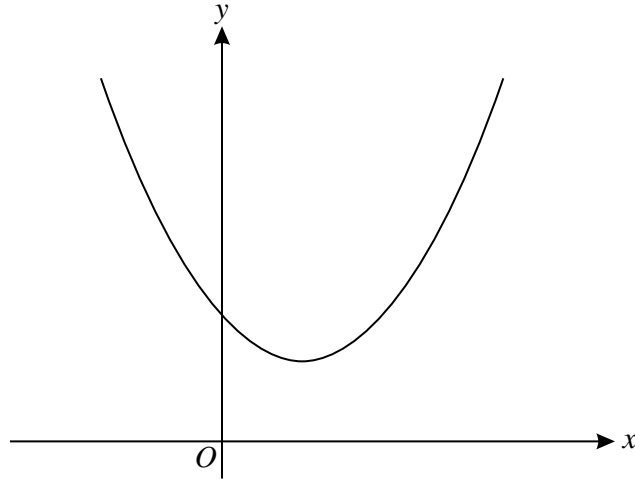

The function g is defined for all real values of x by

$$g(x) = e^{2x} + ke^{-2x},$$

where k is a constant greater than 1. The graph of $y = g(x)$ is shown above. Find the range of g , giving your answer in simplified form. [5]

Copyright Information

OCR is committed to seeking permission to reproduce all third-party content that it uses in its assessment materials. OCR has attempted to identify and contact all copyright holders whose work is used in this paper. To avoid the issue of disclosure of answer-related information to candidates, all copyright acknowledgements are reproduced in the OCR Copyright Acknowledgements Booklet. This is produced for each series of examinations and is freely available to download from our public website (www.ocr.org.uk) after the live examination series. If OCR has unwittingly failed to correctly acknowledge or clear any third-party content in this assessment material, OCR will be happy to correct its mistake at the earliest possible opportunity. For queries or further information please contact the Copyright Team, First Floor, 9 Hills Road, Cambridge CB2 1GE.

OCR is part of the Cambridge Assessment Group; Cambridge Assessment is the brand name of University of Cambridge Local Examinations Syndicate (UCLES), which is itself a department of the University of Cambridge.

1 Find

(i) $\int 6e^{2x+1} dx,$

(ii) $\int 10(2x + 1)^{-1} dx.$

[5]

2 The curve $y = \ln x$ is transformed by:

a reflection in the x -axis,
followed by a stretch with scale factor 3 parallel to the y -axis,
followed by a translation in the positive y -direction by $\ln 4$.

Find the equation of the resulting curve, giving your answer in the form $y = \ln(f(x))$. [4]

3 (a) Given that $7 \sin 2\alpha = 3 \sin \alpha$, where $0^\circ < \alpha < 90^\circ$, find the exact value of $\cos \alpha$. [3]

(b) Given that $3 \cos 2\beta + 19 \cos \beta + 13 = 0$, where $90^\circ < \beta < 180^\circ$, find the exact value of $\sec \beta$. [5]

4 (i) Show by means of suitable sketch graphs that the equation

$$(x - 2)^4 = x + 16$$

has exactly 2 real roots. [3]

(ii) State the value of the smaller root. [1]

(iii) Use the iterative formula

$$x_{n+1} = 2 + \sqrt[4]{x_n + 16},$$

with a suitable starting value, to find the larger root correct to 3 decimal places. [4]

5 The equation of a curve is $y = x^2 \ln(4x - 3)$. Find the exact value of $\frac{d^2y}{dx^2}$ at the point on the curve for which $x = 2$. [8]

6

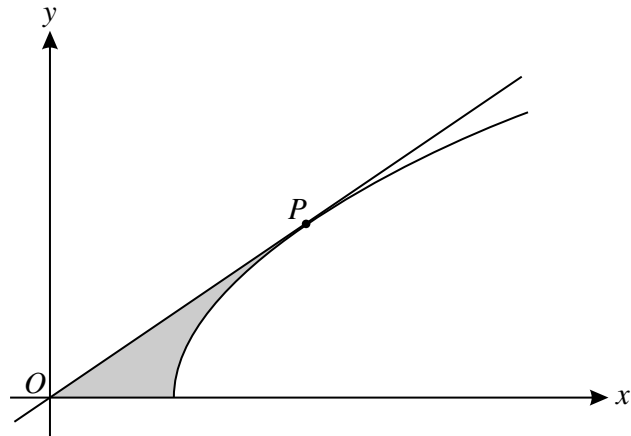

The diagram shows the curve with equation $y = \sqrt{3x-5}$. The tangent to the curve at the point P passes through the origin. The shaded region is bounded by the curve, the x -axis and the line OP . Show that the x -coordinate of P is $\frac{10}{3}$ and hence find the exact area of the shaded region. [9]

7 The functions f , g and h are defined for all real values of x by

$$f(x) = |x|, \quad g(x) = 3x + 5 \quad \text{and} \quad h(x) = gg(x).$$

(i) Solve the equation $g(x+2) = f(-12)$. [3]

(ii) Find $h^{-1}(x)$. [3]

(iii) Determine the values of x for which

$$x + f(x) = 0. \quad [2]$$

8 An experiment involves two substances, Substance 1 and Substance 2, whose masses are changing. The mass, M_1 grams, of Substance 1 at time t hours is given by

$$M_1 = 400e^{-0.014t}.$$

The mass, M_2 grams, of Substance 2 is increasing exponentially and the mass at certain times is shown in the following table.

t (hours)	0	10	20
M_2 (grams)	75	120	192

A critical stage in the experiment is reached at time T hours when the masses of the two substances are equal.

(i) Find the rate at which the mass of Substance 1 is decreasing when $t = 10$, giving your answer in grams per hour correct to 2 significant figures. [3]

(ii) Show that T is the root of an equation of the form $e^{kt} = c$, where the values of the constants k and c are to be stated. [5]

(iii) Hence find the value of T correct to 3 significant figures. [2]

[Question 9 is printed overleaf.]

Jun 2011

9 (i) Prove that $\frac{\sin(\theta - \alpha) + 3 \sin \theta + \sin(\theta + \alpha)}{\cos(\theta - \alpha) + 3 \cos \theta + \cos(\theta + \alpha)} \equiv \tan \theta$ for all values of α . [5]

(ii) Find the exact value of $\frac{4 \sin 149^\circ + 12 \sin 150^\circ + 4 \sin 151^\circ}{3 \cos 149^\circ + 9 \cos 150^\circ + 3 \cos 151^\circ}$. [3]

(iii) It is given that k is a positive constant. Solve, for $0^\circ < \theta < 60^\circ$ and in terms of k , the equation

$$\frac{\sin(6\theta - 15^\circ) + 3 \sin 6\theta + \sin(6\theta + 15^\circ)}{\cos(6\theta - 15^\circ) + 3 \cos 6\theta + \cos(6\theta + 15^\circ)} = k. \quad [4]$$

Copyright Information

OCR is committed to seeking permission to reproduce all third-party content that it uses in its assessment materials. OCR has attempted to identify and contact all copyright holders whose work is used in this paper. To avoid the issue of disclosure of answer-related information to candidates, all copyright acknowledgements are reproduced in the OCR Copyright Acknowledgements Booklet. This is produced for each series of examinations and is freely available to download from our public website (www.ocr.org.uk) after the live examination series.

If OCR has unwittingly failed to correctly acknowledge or clear any third-party content in this assessment material, OCR will be happy to correct its mistake at the earliest possible opportunity.

For queries or further information please contact the Copyright Team, First Floor, 9 Hills Road, Cambridge CB2 1GE.

OCR is part of the Cambridge Assessment Group; Cambridge Assessment is the brand name of University of Cambridge Local Examinations Syndicate (UCLES), which is itself a department of the University of Cambridge.

1 Show that $\int_{\sqrt{2}}^{\sqrt{6}} \frac{2}{x} dx = \ln 3$.

[3]

2

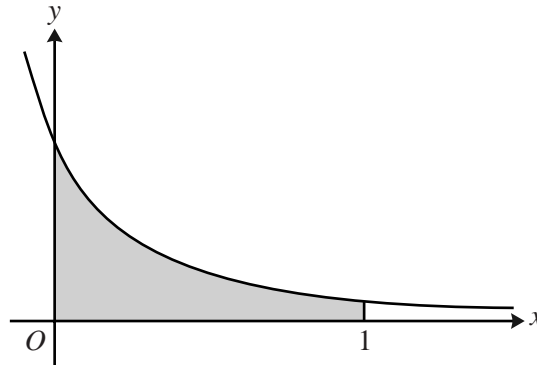

The diagram shows part of the curve $y = \frac{6}{(2x+1)^2}$. The shaded region is bounded by the curve and the lines $x = 0$, $x = 1$ and $y = 0$. Find the exact volume of the solid produced when this shaded region is rotated completely about the x -axis. [5]

3 Find the equation of the normal to the curve $y = \frac{x^2 + 4}{x + 2}$ at the point $(1, \frac{5}{3})$, giving your answer in the form $ax + by + c = 0$, where a , b and c are integers. [7]

4 The acute angles α and β are such that

$$2 \cot \alpha = 1 \quad \text{and} \quad 24 + \sec^2 \beta = 10 \tan \beta.$$

(i) State the value of $\tan \alpha$ and determine the value of $\tan \beta$. [4]

(ii) Hence find the exact value of $\tan(\alpha + \beta)$. [3]

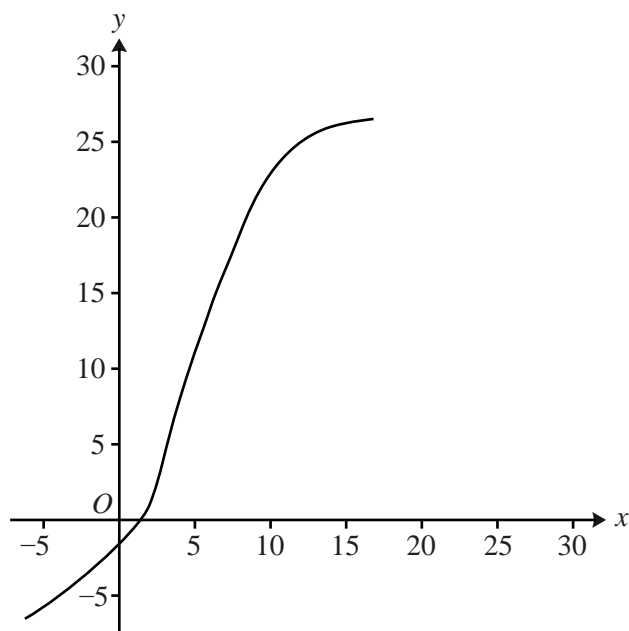

It is given that f is a one-one function defined for all real values. The diagram shows the curve with equation $y = f(x)$. The coordinates of certain points on the curve are shown in the following table.

x	2	4	6	8	10	12	14
y	1	8	14	19	23	25	26

- (i) State the value of $ff(6)$ and the value of $f^{-1}(8)$. [2]
- (ii) On the copy of the diagram, sketch the curve $y = f^{-1}(x)$, indicating how the curves $y = f(x)$ and $y = f^{-1}(x)$ are related. [2]
- (iii) Use Simpson's rule with 6 strips to find an approximation to $\int_2^{14} f(x) dx$. [4]

6

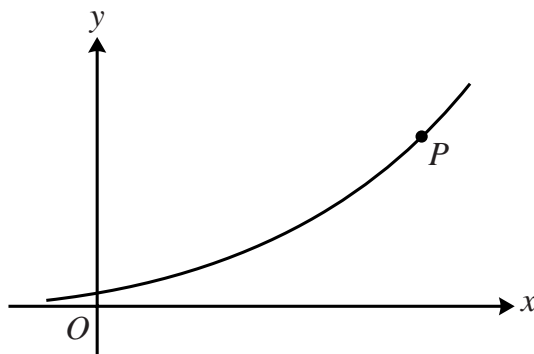

The diagram shows the curve with equation $x = \ln(y^3 + 2y)$. At the point P on the curve, the gradient is 4 and it is given that P is close to the point with coordinates $(7.5, 12)$.

(i) Find $\frac{dx}{dy}$ in terms of y . [2]

(ii) Show that the y -coordinate of P satisfies the equation

$$y = \frac{12y^2 + 8}{y^2 + 2}. \quad [3]$$

(iii) By first using an iterative process based on the equation in part (ii), find the coordinates of P , giving each coordinate correct to 3 decimal places. [5]

7 (i) Substance A is decaying exponentially and its mass is recorded at regular intervals. At time t years, the mass, M grams, of substance A is given by

$$M = 40e^{-0.132t}.$$

(a) Find the time taken for the mass of substance A to decrease to 25% of its value when $t = 0$. [3]

(b) Find the rate at which the mass of substance A is decreasing when $t = 5$. [3]

(ii) Substance B is also decaying exponentially. Initially its mass was 40 grams and, two years later, its mass is 31.4 grams. Find the mass of substance B after a further year. [3]

8 (i) Express $\cos 4\theta$ in terms of $\sin 2\theta$ and hence show that $\cos 4\theta$ can be expressed in the form $1 - k \sin^2 \theta \cos^2 \theta$, where k is a constant to be determined. [3]

(ii) Hence find the exact value of $\sin^2(\frac{1}{24}\pi) \cos^2(\frac{1}{24}\pi)$. [2]

(iii) By expressing $2 \cos^2 2\theta - \frac{8}{3} \sin^2 \theta \cos^2 \theta$ in terms of $\cos 4\theta$, find the greatest and least possible values of

$$2 \cos^2 2\theta - \frac{8}{3} \sin^2 \theta \cos^2 \theta$$

as θ varies.

[5]

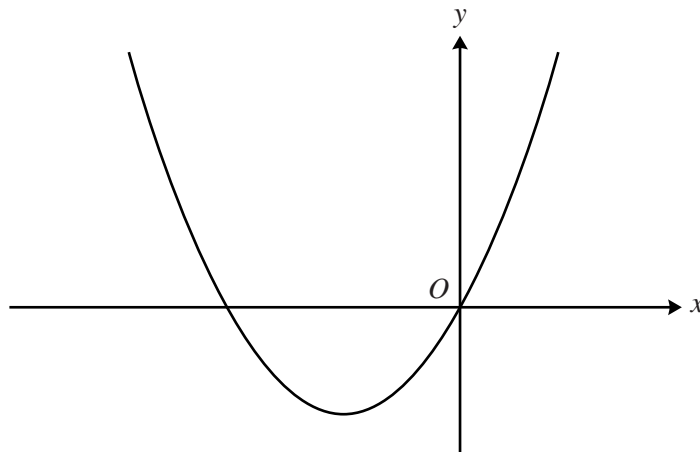

The function f is defined for all real values of x by

$$f(x) = k(x^2 + 4x),$$

where k is a positive constant. The diagram shows the curve with equation $y = f(x)$.

- (i) The curve $y = x^2$ can be transformed to the curve $y = f(x)$ by the following sequence of transformations:
a translation parallel to the x -axis,
a translation parallel to the y -axis,
a stretch.

Give details, in terms of k where appropriate, of these transformations. [5]

- (ii) Find the range of f in terms of k . [2]

- (iii) It is given that there are three distinct values of x which satisfy the equation $|f(x)| = 20$. Find the value of k and determine exactly the three values of x which satisfy the equation in this case. [6]

- 1 Solve the inequality $|2x - 5| > |x + 1|$. [5]
- 2 It is given that $p = e^{280}$ and $q = e^{300}$.
- (i) Use logarithm properties to show that $\ln\left(\frac{ep^2}{q}\right) = 261$. [3]
- (ii) Find the smallest integer n which satisfies the inequality $5^n > pq$. [3]
- 3 It is given that θ is the acute angle such that $\sec\theta \sin\theta = 36 \cot\theta$.
- (i) Show that $\tan\theta = 6$. [3]
- (ii) Hence, using an appropriate formula in each case, find the exact value of
- (a) $\tan(\theta - 45^\circ)$, [2]
- (b) $\tan 2\theta$. [2]
- 4 (a) Show that $\int_0^4 \frac{18}{\sqrt{6x+1}} dx = 24$. [4]
- (b) Find $\int_0^1 (e^x + 2)^2 dx$, giving your answer in terms of e . [4]
- 5 (i) It is given that k is a positive constant. By sketching the graphs of
- $$y = 14 - x^2 \quad \text{and} \quad y = k \ln x$$
- on a single diagram, show that the equation
- $$14 - x^2 = k \ln x$$
- has exactly one real root. [3]
- (ii) The real root of the equation $14 - x^2 = 3 \ln x$ is denoted by α .
- (a) Find by calculation the pair of consecutive integers between which α lies. [3]
- (b) Use the iterative formula $x_{n+1} = \sqrt{14 - 3 \ln x_n}$, with a suitable starting value, to find α . Show the result of each iteration, and give α correct to 2 decimal places. [4]

- 6 The volume, $V \text{ m}^3$, of liquid in a container is given by

$$V = (3h^2 + 4)^{\frac{3}{2}} - 8,$$

where $h \text{ m}$ is the depth of the liquid.

- (i) Find the value of $\frac{dV}{dh}$ when $h = 0.6$, giving your answer correct to 2 decimal places. [4]
- (ii) Liquid is leaking from the container. It is observed that, when the depth of the liquid is 0.6 m , the depth is decreasing at a rate of 0.015 m per hour. Find the rate at which the volume of liquid in the container is decreasing at the instant when the depth is 0.6 m . [3]
- 7 The function f is defined for all real values of x by $f(x) = 2x + 5$. The function g is defined for all real values of x and is such that $g^{-1}(x) = \sqrt[3]{x - a}$, where a is a constant. It is given that $fg^{-1}(12) = 9$. Find the value of a and hence solve the equation $gf(x) = 68$. [7]

- 8 (i) Express $3 \sin \theta + 4 \cos \theta$ in the form $R \sin(\theta + \alpha)$, where $R > 0$ and $0^\circ < \alpha < 90^\circ$. [3]
- (ii) Hence

(a) solve the equation $3 \sin \theta + 4 \cos \theta + 1 = 0$, giving all solutions for which $-180^\circ < \theta < 180^\circ$, [4]

(b) find the values of the positive constants k and c such that

$$-37 \leq k(3 \sin \theta + 4 \cos \theta) + c \leq 43$$

for all values of θ . [4]

- 9 (i) Show that the derivative with respect to y of

$$y \ln(2y) - y$$

is $\ln(2y)$. [3]

(ii)

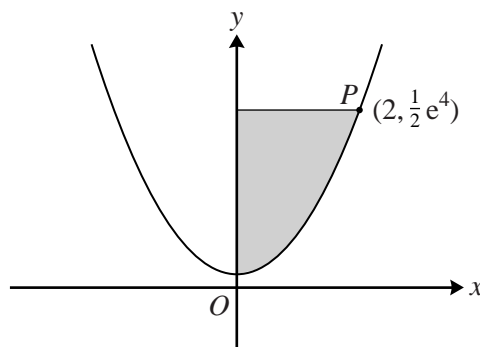

The diagram shows the curve with equation $y = \frac{1}{2}e^{x^2}$. The point $P(2, \frac{1}{2}e^4)$ lies on the curve. The shaded region is bounded by the curve and the lines $x = 0$ and $y = \frac{1}{2}e^4$. Find the exact volume of the solid produced when the shaded region is rotated completely about the y -axis. [6]

- (iii) Hence find the volume of the solid produced when the region bounded by the curve and the lines $x = 0$, $x = 2$ and $y = 0$ is rotated completely about the y -axis. [2]

1 For each of the following curves, find the gradient at the point with x -coordinate 2.

(i) $y = \frac{3x}{2x+1}$ [3]

(ii) $y = \sqrt{4x^2 + 9}$ [3]

2 The acute angle A is such that $\tan A = 2$.

(i) Find the exact value of $\operatorname{cosec} A$. [2]

(ii) The angle B is such that $\tan(A+B) = 3$. Using an appropriate identity, find the exact value of $\tan B$. [3]

3 (a) Given that $|t| = 3$, find the possible values of $|2t - 1|$. [3]

(b) Solve the inequality $|x - \sqrt{2}| > |x + 3\sqrt{2}|$. [4]

4 The mass, m grams, of a substance is increasing exponentially so that the mass at time t hours is given by

$$m = 250e^{0.021t}.$$

(i) Find the time taken for the mass to increase to twice its initial value, and deduce the time taken for the mass to increase to 8 times its initial value. [3]

(ii) Find the rate at which the mass is increasing at the instant when the mass is 400 grams. [3]

5

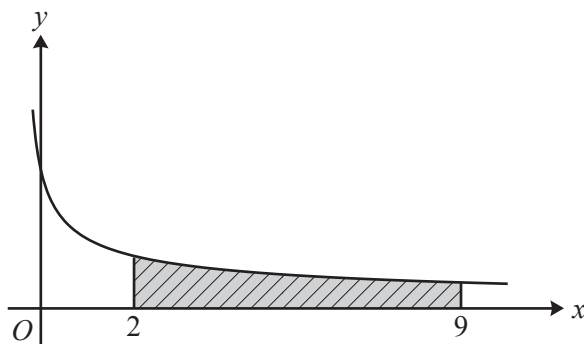

The diagram shows the curve $y = \frac{6}{\sqrt{3x+1}}$. The shaded region is bounded by the curve and the lines $x = 2$, $x = 9$ and $y = 0$.

(i) Show that the area of the shaded region is $4\sqrt{7}$ square units. [4]

(ii) The shaded region is rotated completely about the x -axis. Show that the volume of the solid produced can be written in the form $k\ln 2$, where the exact value of the constant k is to be determined. [5]

- 6 (i) By sketching the curves $y = \ln x$ and $y = 8 - 2x^2$ on a single diagram, show that the equation

$$\ln x = 8 - 2x^2$$

has exactly one real root. [3]

- (ii) Explain how your diagram shows that the root is between 1 and 2. [1]

- (iii) Use the iterative formula

$$x_{n+1} = \sqrt{4 - \frac{1}{2}\ln x_n},$$

with a suitable starting value, to find the root. Show all your working and give the root correct to 3 decimal places. [4]

- (iv) The curves $y = \ln x$ and $y = 8 - 2x^2$ are each translated by 2 units in the positive x -direction and then stretched by scale factor 4 in the y -direction. Find the coordinates of the point where the new curves intersect, giving each coordinate correct to 2 decimal places. [3]

7

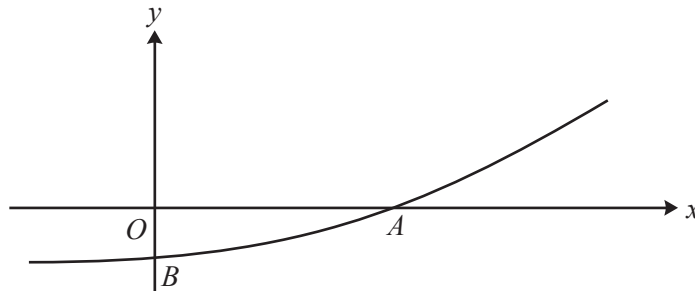

The diagram shows the curve with equation

$$x = (y + 4)\ln(2y + 3).$$

The curve crosses the x -axis at A and the y -axis at B .

- (i) Find an expression for $\frac{dx}{dy}$ in terms of y . [3]
- (ii) Find the gradient of the curve at each of the points A and B , giving each answer correct to 2 decimal places. [5]

- 8 The functions f and g are defined for all real values of x by

$$f(x) = x^2 + 4ax + a^2 \quad \text{and} \quad g(x) = 4x - 2a,$$

where a is a positive constant.

- (i) Find the range of f in terms of a . [4]
- (ii) Given that $fg(3) = 69$, find the value of a and hence find the value of x such that $g^{-1}(x) = x$. [6]

9 (i) Prove that

$$\cos^2(\theta + 45^\circ) - \frac{1}{2}(\cos 2\theta - \sin 2\theta) \equiv \sin^2 \theta. \quad [4]$$

(ii) Hence solve the equation

$$6 \cos^2\left(\frac{1}{2}\theta + 45^\circ\right) - 3(\cos \theta - \sin \theta) = 2$$

for $-90^\circ < \theta < 90^\circ$.

[3]

(iii) It is given that there are two values of θ , where $-90^\circ < \theta < 90^\circ$, satisfying the equation

$$6 \cos^2\left(\frac{1}{3}\theta + 45^\circ\right) - 3\left(\cos \frac{2}{3}\theta - \sin \frac{2}{3}\theta\right) = k,$$

where k is a constant. Find the set of possible values of k .

[3]

Copyright Information

OCR is committed to seeking permission to reproduce all third-party content that it uses in its assessment materials. OCR has attempted to identify and contact all copyright holders whose work is used in this paper. To avoid the issue of disclosure of answer-related information to candidates, all copyright acknowledgements are reproduced in the OCR Copyright Acknowledgements Booklet. This is produced for each series of examinations and is freely available to download from our public website (www.ocr.org.uk) after the live examination series.

If OCR has unwittingly failed to correctly acknowledge or clear any third-party content in this assessment material, OCR will be happy to correct its mistake at the earliest possible opportunity.

For queries or further information please contact the Copyright Team, First Floor, 9 Hills Road, Cambridge CB2 1GE.

OCR is part of the Cambridge Assessment Group; Cambridge Assessment is the brand name of University of Cambridge Local Examinations Syndicate (UCLES), which is itself a department of the University of Cambridge.

1 Find

(i) $\int (4 - 3x)^7 dx,$

(ii) $\int (4 - 3x)^{-1} dx.$

[5]

2 Using an appropriate identity in each case, find the possible values of

(i) $\sin \alpha$ given that $4 \cos 2\alpha = \sin^2 \alpha,$

[3]

(ii) $\sec \beta$ given that $2 \tan^2 \beta = 3 + 9 \sec \beta.$

[4]

3

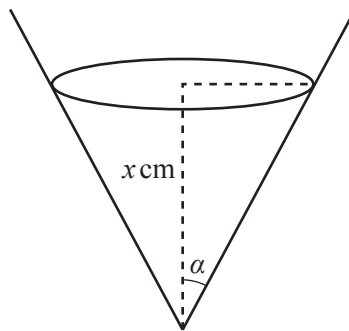

The diagram shows a container in the form of a right circular cone. The angle between the axis and the slant height is α , where $\alpha = \tan^{-1}(\frac{1}{2})$. Initially the container is empty, and then liquid is added at the rate of 14 cm^3 per minute. The depth of liquid in the container at time t minutes is x cm.

(i) Show that the volume, $V \text{ cm}^3$, of liquid in the container when the depth is x cm is given by

$$V = \frac{1}{12} \pi x^3.$$

[The volume of a cone is $\frac{1}{3} \pi r^2 h.$]

[2]

(ii) Find the rate at which the depth of the liquid is increasing at the instant when the depth is 8 cm. Give your answer in cm per minute correct to 2 decimal places.

[3]

4 Find the exact value of the gradient of the curve

$$y = \sqrt{4x - 7} + \frac{4x}{2x + 1}$$

at the point for which $x = 4.$

[6]

5 (i) Give full details of a sequence of two transformations needed to transform the graph of $y = |x|$ to the graph of $y = |2(x + 3)|.$

[3]

(ii) Solve the inequality $|x| > |2(x + 3)|$, showing all your working.

[5]

June 2013

- 6 The value of $\int_0^8 \ln(3 + x^2) dx$ obtained by using Simpson's rule with four strips is denoted by A .
- (i) Find the value of A correct to 3 significant figures. [4]
- (ii) Explain why an approximate value of $\int_0^8 \ln(9 + 6x^2 + x^4) dx$ is $2A$. [2]
- (iii) Explain why an approximate value of $\int_0^8 \ln(3e + ex^2) dx$ is $A + 8$. [2]

7

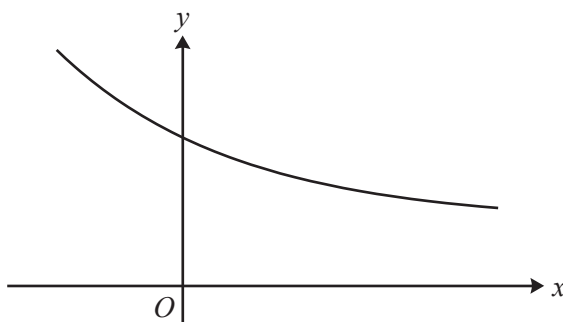

The diagram shows the curve $y = f(x)$, where f is the function defined for all real values of x by

$$f(x) = 3 + 4e^{-x}.$$

- (i) State the range of f . [1]
- (ii) Find an expression for $f^{-1}(x)$, and state the domain and range of f^{-1} . [4]
- (iii) The straight line $y = x$ meets the curve $y = f(x)$ at the point P . By using an iterative process based on the equation $x = f(x)$, with a starting value of 3, find the coordinates of the point P . Show all your working and give each coordinate correct to 3 decimal places. [4]
- (iv) How is the point P related to the curves $y = f(x)$ and $y = f^{-1}(x)$? [1]
- 8 (i) Express $4 \cos \theta - 2 \sin \theta$ in the form $R \cos(\theta + \alpha)$, where $R > 0$ and $0^\circ < \alpha < 90^\circ$. [3]
- (ii) Hence
- (a) solve the equation $4 \cos \theta - 2 \sin \theta = 3$ for $0^\circ < \theta < 360^\circ$, [4]
- (b) determine the greatest and least values of
- $$25 - (4 \cos \theta - 2 \sin \theta)^2$$
- as θ varies, and, in each case, find the smallest positive value of θ for which that value occurs. [5]

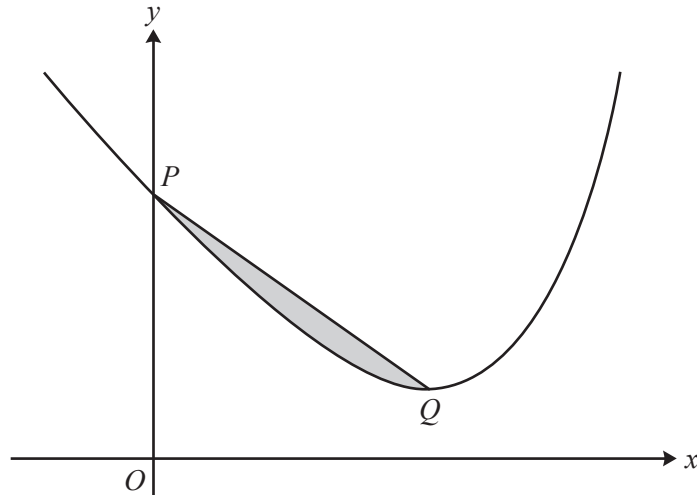

The diagram shows the curve

$$y = e^{2x} - 18x + 15.$$

The curve crosses the y -axis at P and the minimum point is Q . The shaded region is bounded by the curve and the line PQ .

- (i) Show that the x -coordinate of Q is $\ln 3$. [3]
- (ii) Find the exact area of the shaded region. [8]

Copyright Information

OCR is committed to seeking permission to reproduce all third-party content that it uses in its assessment materials. OCR has attempted to identify and contact all copyright holders whose work is used in this paper. To avoid the issue of disclosure of answer-related information to candidates, all copyright acknowledgements are reproduced in the OCR Copyright Acknowledgements Booklet. This is produced for each series of examinations and is freely available to download from our public website (www.ocr.org.uk) after the live examination series.

If OCR has unwittingly failed to correctly acknowledge or clear any third-party content in this assessment material, OCR will be happy to correct its mistake at the earliest possible opportunity.

For queries or further information please contact the Copyright Team, First Floor, 9 Hills Road, Cambridge CB2 1GE.

OCR is part of the Cambridge Assessment Group; Cambridge Assessment is the brand name of University of Cambridge Local Examinations Syndicate (UCLES), which is itself a department of the University of Cambridge.

1 Given that $y = 4x^2 \ln x$, find the value of $\frac{d^2y}{dx^2}$ when $x = e^2$. [5]

2 By first using appropriate identities, solve the equation

$$5 \cos 2\theta \operatorname{cosec} \theta = 2$$

for $0^\circ < \theta < 180^\circ$. [6]

3 (i) Use Simpson's rule with four strips to find an approximation to

$$\int_0^2 e^{\sqrt{x}} dx,$$

giving your answer correct to 3 significant figures. [4]

(ii) Deduce an approximation to $\int_0^2 (1 + 10e^{\sqrt{x}}) dx$. [2]

4 The functions f and g are defined for all real values of x by

$$f(x) = 2x^3 + 4 \quad \text{and} \quad g(x) = \sqrt[3]{x-10}.$$

(i) Evaluate $f^{-1}(-50)$. [2]

(ii) Show that $fg(x) = 2x - 16$. [2]

(iii) Differentiate $gf(x)$ with respect to x . [3]

5 (a) The mass, M grams, of a substance at time t years is given by

$$M = 58e^{-0.33t}.$$

Find the rate at which the mass is decreasing at the instant when $t = 4$. Give your answer correct to 2 significant figures. [3]

(b) The mass of a second substance is increasing exponentially. The initial mass is 42.0 grams and, 6 years later, the mass is 51.8 grams. Find the mass at a time 24 years after the initial value. [4]

6

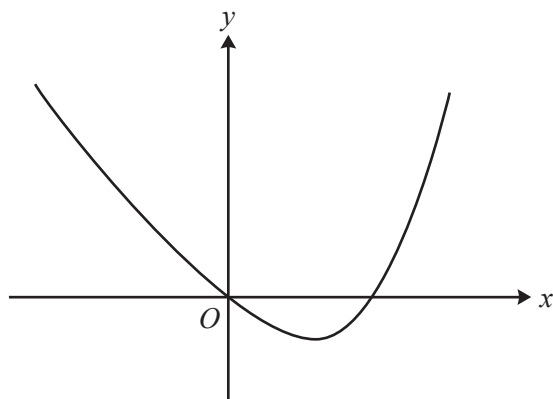

The diagram shows the curve $y = x^4 - 8x$.

- (i) By sketching a second curve on the copy of the diagram, show that the equation

$$x^4 + x^2 - 8x - 9 = 0$$

has two real roots. State the equation of the second curve. [2]

- (ii) The larger root of the equation $x^4 + x^2 - 8x - 9 = 0$ is denoted by α .

- (a) Show by calculation that $2.1 < \alpha < 2.2$. [2]

- (b) Use an iterative process based on the equation

$$x = \sqrt[4]{9 + 8x - x^2},$$

with a suitable starting value, to find α correct to 3 decimal places. Give the result of each step of the iterative process. [4]

7

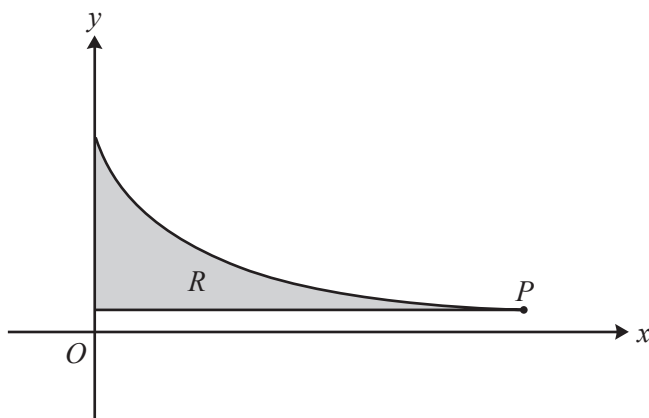

The diagram shows the curve $y = \sqrt{\frac{3}{4x+1}}$ for $0 \leq x \leq 20$. The point P on the curve has coordinates $(20, \frac{1}{9}\sqrt{3})$. The shaded region R is enclosed by the curve and the lines $x = 0$ and $y = \frac{1}{9}\sqrt{3}$.

- (i) Find the exact area of R . [4]

- (ii) Find the exact volume of the solid obtained when R is rotated completely about the x -axis. [6]

8

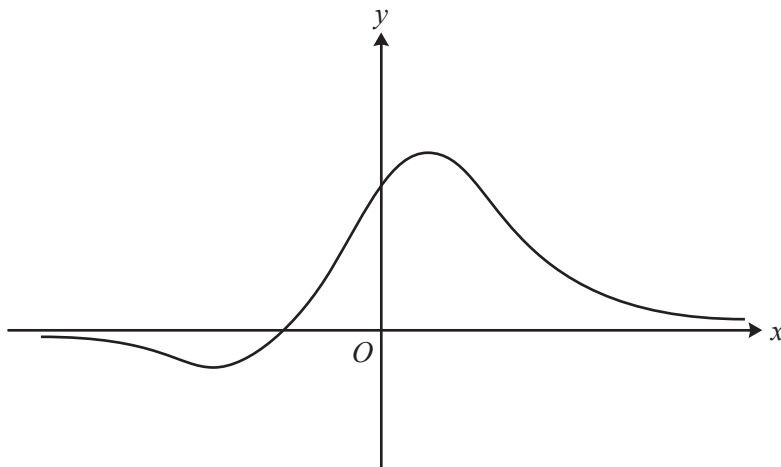

The diagram shows the curve $y = \frac{2x+4}{x^2+5}$.

(i) Find $\frac{dy}{dx}$ and hence find the coordinates of the two stationary points. [6]

(ii) The function g is defined for all real values of x by

$$g(x) = \left| \frac{2x+4}{x^2+5} \right|.$$

(a) Sketch the curve $y = g(x)$ and state the range of g . [3]

(b) It is given that the equation $g(x) = k$, where k is a constant, has exactly two distinct real roots. Write down the set of possible values of k . [2]

9 (i) Express $5 \cos(\theta - 60^\circ) + 3 \cos \theta$ in the form $R \sin(\theta + \alpha)$, where $R > 0$ and $0^\circ < \alpha < 90^\circ$. [4]

(ii) Hence

(a) give details of the transformations needed to transform the curve $y = 5 \cos(\theta - 60^\circ) + 3 \cos \theta$ to the curve $y = \sin \theta$, [3]

(b) find the smallest positive value of β satisfying the equation

$$5 \cos\left(\frac{1}{3}\beta - 40^\circ\right) + 3 \cos\left(\frac{1}{3}\beta + 20^\circ\right) = 3. \quad [5]$$

END OF QUESTION PAPER



Copyright Information

OCR is committed to seeking permission to reproduce all third-party content that it uses in its assessment materials. OCR has attempted to identify and contact all copyright holders whose work is used in this paper. To avoid the issue of disclosure of answer-related information to candidates, all copyright acknowledgements are reproduced in the OCR Copyright Acknowledgements Booklet. This is produced for each series of examinations and is freely available to download from our public website (www.ocr.org.uk) after the live examination series.

If OCR has unwittingly failed to correctly acknowledge or clear any third-party content in this assessment material, OCR will be happy to correct its mistake at the earliest possible opportunity.

For queries or further information please contact the Copyright Team, First Floor, 9 Hills Road, Cambridge CB2 1GE.

OCR is part of the Cambridge Assessment Group; Cambridge Assessment is the brand name of University of Cambridge Local Examinations Syndicate (UCLES), which is itself a department of the University of Cambridge.