

Paper Reference(s)

6677**Edexcel GCE****Mechanics M1****(New Syllabus)****Advanced/Advanced Subsidiary****Friday 12 January 2001 – Afternoon****Time: 1 hour 30 minutes****Materials required for examination**Answer Book (AB16)
Graph Paper (GP02)
Mathematical Formulae**Items included with question papers**

Nil

Candidates may use any calculator EXCEPT those with the facility for symbolic algebra, differentiation and/or integration. Thus candidates may NOT use calculators such as the Texas Instruments TI 89, TI 92, Casio CFX 9970G, Hewlett Packard HP 48G.

Instructions to Candidates

In the boxes on the answer book, write the name of the examining body (Edexcel), your centre number, candidate number, the unit title (Mechanics M1), the paper reference (6677), your surname, other name and signature.

Whenever a numerical value of g is required, take $g = 9.8 \text{ m s}^{-2}$.

When a calculator is used, the answer should be given to an appropriate degree of accuracy.

Information for Candidates

A booklet 'Mathematical Formulae and Statistical Tables' is provided.

Full marks may be obtained for answers to ALL questions.

This paper has seven questions. Pages 6, 7 and 8 are blank.

Advice to Candidates

You must ensure that your answers to parts of questions are clearly labelled.

You must show sufficient working to make your methods clear to the Examiner. Answers without working may gain no credit.

N6992

83019/R6677 3/3/3/3/3200
This publication may only be reproduced in accordance with Edexcel copyright policy.
Edexcel Foundation is a registered charity. ©2001 Edexcel

1.

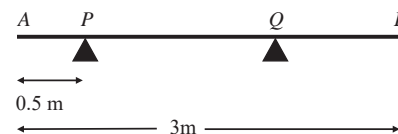

Fig. 1

A uniform rod AB has weight 70 N and length 3 m . It rests in a horizontal position on two smooth supports placed at P and Q , where $AP = 0.5 \text{ m}$, as shown in Fig. 1. The reaction on the rod at P has magnitude 20 N . Find

(a) the magnitude of the reaction on the rod at Q , (2 marks)

(b) the distance AQ . (4 marks)

2.

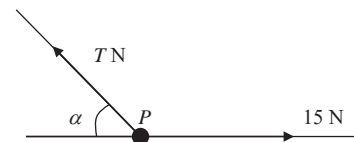

Fig. 2

A particle P of mass 2 kg is held in equilibrium under gravity by two light inextensible strings. One string is horizontal and the other is inclined at an angle α to the horizontal, as shown in Fig. 2. The tension in the horizontal string is 15 N . The tension in the other string is T newtons.

(a) Find the size of the angle α . (6 marks)

(b) Find the value of T . (2 marks)

N6993

2

3.

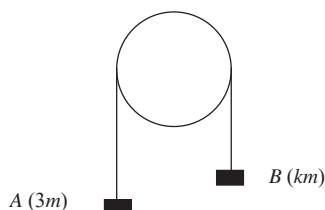

Fig. 3

Two particles A and B have masses $3m$ and km respectively, where $k > 3$. They are connected by a light inextensible string which passes over a smooth fixed pulley. The system is released from rest with the string taut and the hanging parts of the string vertical, as shown in Fig. 3. While the particles are moving freely, A has an acceleration of magnitude $\frac{2}{5}g$.

- (a) Find, in terms of m and g , the tension in the string. **(3 marks)**
- (b) State why B also has an acceleration of magnitude $\frac{2}{5}g$. **(1 mark)**
- (c) Find the value of k . **(4 marks)**
- (d) State how you have used the fact that the string is light. **(1 mark)**

4. A particle P moves in a straight line with constant velocity. Initially P is at the point A with position vector $(2\mathbf{i} - \mathbf{j})$ m relative to a fixed origin O , and 2 s later it is at the point B with position vector $(6\mathbf{i} + \mathbf{j})$ m.

- (a) Find the velocity of P . **(3 marks)**
- (b) Find, in degrees to one decimal place, the size of the angle between the direction of motion of P and the vector \mathbf{i} . **(2 marks)**

Three seconds after it passes B the particle P reaches the point C .

- (c) Find, in m to one decimal place, the distance OC . **(4 marks)**

5. Two small balls A and B have masses 0.6 kg and 0.2 kg respectively. They are moving towards each other in opposite directions on a horizontal table when they collide directly. Immediately before the collision, the speed of A is 4.5 m s⁻¹ and the speed of B is 3 m s⁻¹. Immediately after the collision, A and B move in the same direction and the speed of B is twice the speed of A .

By modelling the balls as particles, find

- (a) the speed of B immediately after the collision, **(4 marks)**
- (b) the magnitude of the impulse exerted on B in the collision, stating the units in which your answer is given. **(3 marks)**

The table is rough. After the collision, B moves a distance of 2 m on the table before coming to rest.

- (c) Find the coefficient of friction between B and the table. **(6 marks)**

6. A parachutist drops from a helicopter H and falls vertically from rest towards the ground. Her parachute opens 2 s after she leaves H and her speed then reduces to 4 m s⁻¹. For the first 2 s her motion is modelled as that of a particle falling freely under gravity. For the next 5 s the model is motion with constant deceleration, so that her speed is 4 m s⁻¹ at the end of this period. For the rest of the time before she reaches the ground, the model is motion with constant speed of 4 m s⁻¹.

- (a) Sketch a speed-time graph to illustrate her motion from H to the ground. **(3 marks)**
- (b) Find her speed when the parachute opens. **(2 marks)**

A safety rule states that the helicopter must be high enough to allow the parachute to open and for the speed of a parachutist to reduce to 4 m s⁻¹ before reaching the ground. Using the assumptions made in the above model,

- (c) find the minimum height of H for which the woman can make a drop without breaking this safety rule. **(5 marks)**

Given that H is 125 m above the ground when the woman starts her drop,

- (d) find the total time taken for her to reach the ground. **(4 marks)**
- (e) State one way in which the model could be refined to make it more realistic. **(1 mark)**

7. A sledge of mass 78 kg is pulled up a slope by means of a rope. The slope is modelled as a rough plane inclined at an angle α to the horizontal, where $\tan \alpha = \frac{5}{12}$. The rope is modelled as light and inextensible and is in a line of greatest slope of the plane. The coefficient of friction between the sledge and the slope is 0.25. Given that the sledge is accelerating up the slope with acceleration 0.5 m s^{-2} ,

(a) find the tension in the rope. (9 marks)

The rope suddenly breaks. Subsequently the sledge comes to instantaneous rest and then starts sliding down the slope.

(b) Find the acceleration of the sledge down the slope *after* it has come to instantaneous rest. (6 marks)

END

Paper Reference(s)

6677

Edexcel GCE

Mechanics M1

(New Syllabus)

Advanced/Advanced Subsidiary

Thursday 7 June 2001 – Afternoon

Time: 1 hour 30 minutes

Materials required for examination

Answer Book (AB16)
Mathematical Formulae (Lilac)
Graph Paper (ASG2)

Items included with question papers

Nil

Candidates may use any calculator EXCEPT those with the facility for symbolic algebra, differentiation and/or integration. Thus candidates may NOT use calculators such as the Texas Instruments TI 89, TI 92, Casio CFX 9970G, Hewlett Packard HP 48G

Instructions to Candidates

In the boxes on the answer book, write the name of the examining body (Edexcel), your centre number, candidate number, the unit title (Mechanics M1), the paper reference (6677), your surname, other name and signature.

Whenever a numerical value of g is required, take $g = 9.8 \text{ m s}^{-2}$.

When a calculator is used, the answer should be given to an appropriate degree of accuracy.

Information for Candidates

A booklet 'Mathematical Formulae and Statistical Tables' is provided.

Full marks may be obtained for answers to ALL questions.

This paper has seven questions.

Advice to Candidates

You must ensure that your answers to parts of questions are clearly labelled.

You must show sufficient working to make your methods clear to the Examiner. Answers without working may gain no credit.

1. Two small balls *A* and *B* have masses 0.5 kg and 0.2 kg respectively. They are moving towards each other in opposite directions on a smooth horizontal table when they collide directly. Immediately before the collision, the speed of *A* is 3 m s^{-1} and the speed of *B* is 2 m s^{-1} . The speed of *A* immediately after the collision is 1.5 m s^{-1} . The direction of the motion of *A* is unchanged as a result of the collision.

By modelling the balls as particles, find

- (a) the speed of *B* immediately after the collision, (3)
 (b) the magnitude of the impulse exerted on *B* in the collision. (3)
-

2. **Figure 1**

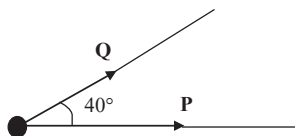

Two forces **P** and **Q**, act on a particle. The force **P** has magnitude 5 N and the force **Q** has magnitude 3 N. The angle between the directions of **P** and **Q** is 40° , as shown in Fig. 1. The resultant of **P** and **Q** is **F**.

- (a) Find, to 3 significant figures, the magnitude of **F**. (5)
 (b) Find, in degrees to 1 decimal place, the angle between the directions of **F** and **P**. (3)
-

3. **Figure 2**

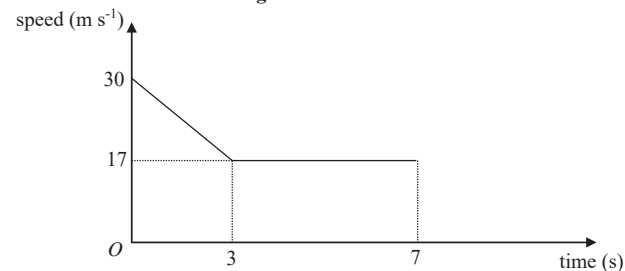

A car of mass 1200 kg moves along a straight horizontal road. In order to obey a speed restriction, the brakes of the car are applied for 3 s, reducing the car's speed from 30 m s^{-1} to 17 m s^{-1} . The brakes are then released and the car continues at a constant speed of 17 m s^{-1} for a further 4 s. Figure 2 shows a sketch of the speed-time graph of the car during the 7 s interval. The graph consists of two straight line segments.

- (a) Find the total distance moved by the car during this 7 s interval. (4)
 (b) Explain briefly how the speed-time graph shows that, when the brakes are applied, the car experiences a constant retarding force. (2)
 (c) Find the magnitude of this retarding force. (3)
-

4.

Figure 3

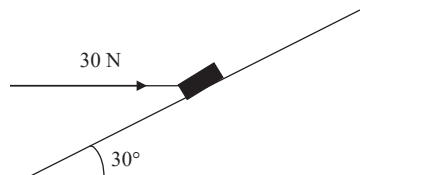

A small parcel of mass 3 kg is held in equilibrium on a rough plane by the action of a horizontal force of magnitude 30 N acting in a vertical plane through a line of greatest slope. The plane is inclined at an angle of 30° to the horizontal, as shown in Fig. 3. The parcel is modelled as a particle. The parcel is on the point of moving *up* the slope.

- (a) Draw a diagram showing all the forces acting on the parcel. (2)
- (b) Find the normal reaction on the parcel. (4)
- (c) Find the coefficient of friction between the parcel and the plane. (5)

5.

Figure 4

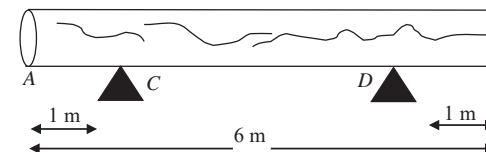

A large log AB is 6 m long. It rests in a horizontal position on two smooth supports C and D , where $AC = 1$ m and $BD = 1$ m, as shown in Figure 4. David needs an estimate of the weight of the log, but the log is too heavy to lift off both supports. When David applies a force of magnitude 1500 N vertically upwards to the log at A , the log is about to tilt about D .

- (a) State the value of the reaction on the log at C for this case. (1)
- David initially models the log as uniform rod. Using this model,
- (b) estimate the weight of the log (3)

The shape of the log convinces David that his initial modelling assumption is too simple. He removes the force at A and applies a force acting vertically upwards at B . He finds that the log is about to tilt about C when this force has magnitude 1000 N. David now models the log as a non-uniform rod, with the distance of the centre of mass of the log from C as x metres. Using this model, find

- (c) a new estimate for the weight of the log, (6)
- (d) the value of x . (2)
- (e) State how you have used the modeling assumption that the log is a rod. (1)

6. A breakdown van of mass 2000 kg is towing a car of mass 1200 kg along a straight horizontal road. The two vehicles are joined by a tow bar which remains parallel to the road. The van and the car experience constant resistances to motion of magnitudes 800 N and 240 N respectively. There is a constant driving force acting on the van of 2320 N. Find

(a) the magnitude of the acceleration of the van and the car, (3)

(b) the tension in the tow bar. (4)

The two vehicles come to a hill inclined at an angle α to the horizontal, where $\sin \alpha = \frac{1}{20}$. The driving force and the resistances to the motion are unchanged.

(c) Find the magnitude of the acceleration of the van and the car as they move up the hill and state whether their speed increases or decreases. (6)

7. [In this question, the horizontal unit vectors \mathbf{i} and \mathbf{j} are directed due east and north respectively]

A mountain rescue post O receives a distress call via a mobile phone from a walker who has broken a leg and cannot move. The walker says he is by a pipeline and he can also see a radio mast which he believes to be south-west of him. The pipeline is known to run north-south for a long distance through the point with position vector $6\mathbf{i}$ km, relative to O . The radio mast is known to be at the point with position vector $2\mathbf{j}$ km, relative to O .

(a) Using the information supplied by the walker, write down his position vector in the form $(a\mathbf{i} + b\mathbf{j})$. (2)

The rescue party moves at a horizontal speed of 5 km h^{-1} . The leader of the party wants to give the walker an idea of how long it will take for the rescue party to arrive.

(b) Calculate how long it will take for the rescue party to reach the walker's estimated position. (3)

The rescue party sets out and walks straight towards the walker's estimated position at a constant horizontal speed of 5 km h^{-1} . After the party has travelled for one hour, the walker rings again. He is very apologetic and says that he now realises that the radio mast is in fact *north-west* of his position

(c) Find the position vector of the walker. (3)

(d) Find in degrees to one decimal place, the bearing on which the rescue party should now travel in order to reach the walker directly. (7)

END

Paper Reference(s)

6677**Edexcel GCE****Mechanics M1****(New Syllabus)****Advanced/Advanced Subsidiary****Monday 14 January 2002 – Afternoon****Time: 1 hour 30 minutes****Materials required for examination**

Answer Book (AB16)

Mathematical Formulae (Lilac)

Graph Paper (ASG2)

Items included with question papers

Nil

Candidates may use any calculator EXCEPT those with the facility for symbolic algebra, differentiation and/or integration. Thus candidates may NOT use calculators such as the Texas Instruments TI 89, TI 92, Casio CFX 9970G, Hewlett Packard HP 48G

Instructions to Candidates

In the boxes on the answer book, write the name of the examining body (Edexcel), your centre number, candidate number, the unit title (Mechanics M1), the paper reference (6677), your surname, other name and signature.

Whenever a numerical value of g is required, take $g = 9.8 \text{ m s}^{-2}$.

When a calculator is used, the answer should be given to an appropriate degree of accuracy.

Information for Candidates

A booklet 'Mathematical Formulae and Statistical Tables' is provided.

Full marks may be obtained for answers to ALL questions.

This paper has eight questions. Pages 7 and 8 are blank.

Advice to Candidates

You must ensure that your answers to parts of questions are clearly labelled.

You must show sufficient working to make your methods clear to the Examiner. Answers without working may gain no credit.

1. A ball of mass 0.3 kg is moving vertically downwards with speed 8 m s^{-1} when it hits the floor which is smooth and horizontal. It rebounds vertically from the floor with speed 6 m s^{-1} . Find the magnitude of the impulse exerted by the floor on the ball. (3)
-

2. A railway truck A of mass 1800 kg is moving along a straight horizontal track with speed 4 m s^{-1} . It collides directly with a stationary truck B of mass 1200 kg on the same track. In the collision, A and B are coupled and move off together.

(a) Find the speed of the trucks immediately after the collision. (3)

After the collision, the trucks experience a constant resistive force of magnitude R newtons. They come to rest 8 s after the collision.

(b) Find R . (3)

3. A racing car moves with constant acceleration along a straight horizontal road. It passes the point O with speed 12 m s^{-1} . It passes the point A 4 s later with speed 60 m s^{-1} .

(a) Show that the acceleration of the car is 12 m s^{-2} . (2)

(b) Find the distance OA . (3)

The point B is the mid-point of OA .

(c) Find, to 3 significant figures, the speed of the car when it passes B . (3)

4. A motor scooter and a van set off along a straight road. They both start from rest at the same time and level with each other. The scooter accelerates with constant acceleration until it reaches its top speed of 20 m s^{-1} . It then maintains a constant speed of 20 m s^{-1} . The van accelerates with constant acceleration for 10 s until it reaches its top speed $V \text{ m s}^{-1}$, $V > 20$. It then maintains a constant speed of $V \text{ m s}^{-1}$. The van draws level with the scooter when the scooter has been travelling for 40 s at its top speed. The total distance travelled by each vehicle is then 850 m.

(a) Sketch on the same diagram the speed-time graphs of both vehicles to illustrate their motion from the time when they start to the time when the van overtakes the scooter.

(b) Find the time for which the scooter is accelerating. (3)

(c) Find the top speed of the van. (3)

(d) Find the top speed of the van. (3)

TURN OVER FOR QUESTION 5

5.

Figure 1

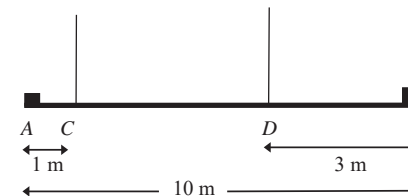

A heavy uniform steel girder AB has length 10 m. A load of weight 150 N is attached to the girder at A and a load of weight 250 N is attached to the girder at B . The loaded girder hangs in equilibrium in a horizontal position, held by two vertical steel cables attached to the girder at the points C and D , where $AC = 1 \text{ m}$ and $DB = 3 \text{ m}$, as shown in Fig. 1. The girder is modelled as a uniform rod, the loads as particles and the cables as light inextensible strings. The tension in the cable at D is three times the tension in the cable at C .

(a) Draw a diagram showing all the forces acting on the girder. (2)

Find (2)

(b) the tension in the cable at C , (5)

(c) the weight of the girder. (2)

(d) Explain how you have used the fact that the girder is uniform. (1)

6. A particle P , of mass 3 kg, moves under the action of two constant forces $(6\mathbf{i} + 2\mathbf{j}) \text{ N}$ and $(3\mathbf{i} - 5\mathbf{j}) \text{ N}$.

(a) Find, in the form $(a\mathbf{i} + b\mathbf{j}) \text{ N}$, the resultant force \mathbf{F} acting on P . (1)

(b) Find, in degrees to one decimal place, the angle between \mathbf{F} and \mathbf{j} . (3)

(c) Find the acceleration of P , giving your answer as a vector. (2)

The initial velocity of P is $(-2\mathbf{i} + \mathbf{j}) \text{ m s}^{-1}$.

(d) Find, to 3 significant figures, the speed of P after 2 s. (5)

7.

Figure 2

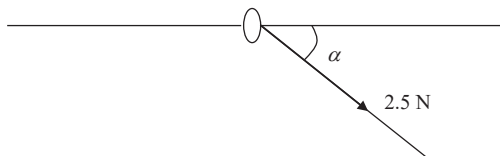

A ring of mass 0.3 kg is threaded on a fixed, rough horizontal curtain pole. A light inextensible string is attached to the ring. The string and the pole lie in the same vertical plane. The ring is pulled downwards by the string which makes an angle α to the horizontal, where $\tan \alpha = \frac{3}{4}$ as shown in Fig. 2. The tension in the string is 2.5 N . Given that, in this position, the ring is in limiting equilibrium,

(a) find the coefficient of friction between the ring and the pole.

(8)

Figure 3

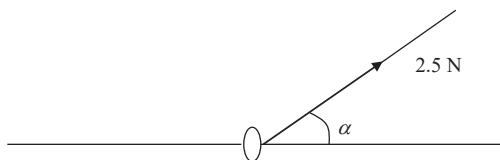

The direction of the string is now altered so that the ring is pulled upwards. The string lies in the same vertical plane as before and again makes an angle α with the horizontal, as shown in Fig. 3. The tension in the string is again 2.5 N .

(b) Find the normal reaction exerted by the pole on the ring.

(2)

(c) State whether the ring is in equilibrium in the position shown in Fig. 3, giving a brief justification for your answer. You need make no further detailed calculation of the forces acting.

(2)

8.

Figure 4

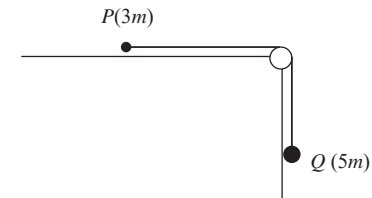

Two particles P and Q have masses $3m$ and $5m$ respectively. They are connected by a light inextensible string which passes over a small smooth light pulley fixed at the edge of a rough horizontal table. Particle P lies on the table and particle Q hangs freely below the pulley, as shown in Fig. 4. The coefficient of friction between P and the table is 0.6 . The system is released from rest with the string taut. For the period before Q hits the floor or P reaches the pulley,

(a) write down an equation of motion for each particle separately,

(4)

(b) find, in terms of g , the acceleration of Q ,

(4)

(c) find, in terms of m and g , the tension in the string.

(2)

When Q has moved a distance h , it hits the floor and the string becomes slack. Given that P remains on the table during the subsequent motion and does not reach the pulley,

(d) find, in terms of h , the distance moved by P after the string becomes slack until P comes to rest.

(6)

END

Paper Reference(s)

6677**Edexcel GCE****Mechanics M1****(New Syllabus)****Advanced/Advanced Subsidiary****Thursday 23 May 2002 – Afternoon****Time: 1 hour 30 minutes****Materials required for examination**

Answer Book (AB16)

Mathematical Formulae (Lilac)

Graph Paper (ASG2)

Items included with question papers

Nil

Candidates may use any calculator EXCEPT those with the facility for symbolic algebra, differentiation and/or integration. Thus candidates may NOT use calculators such as the Texas Instruments TI 89, TI 92, Casio CFX 9970G, Hewlett Packard HP 48G

Instructions to Candidates

In the boxes on the answer book, write the name of the examining body (Edexcel), your centre number, candidate number, the unit title (Mechanics M1), the paper reference (6677), your surname, other name and signature.

Whenever a numerical value of g is required, take $g = 9.8 \text{ m s}^{-2}$.

When a calculator is used, the answer should be given to an appropriate degree of accuracy.

Information for Candidates

A booklet 'Mathematical Formulae and Statistical Tables' is provided.

Full marks may be obtained for answers to ALL questions.

This paper has seven questions. Pages 7 and 8 are blank.

Advice to Candidates

You must ensure that your answers to parts of questions are clearly labelled.

You must show sufficient working to make your methods clear to the Examiner. Answers without working may gain no credit.

1. A car moves with constant acceleration along a straight horizontal road. The car passes the point A with speed 5 m s^{-1} and 4 s later it passes the point B , where $AB = 50\text{m}$.

(a) Find the acceleration of the car.

(3)

When the car passes the point C , it has speed 30 m s^{-1} .

(b) Find the distance AC .

(3)

2. The masses of two particles A and B are 0.5 kg and $m \text{ kg}$ respectively. The particles are moving on a smooth horizontal table in opposite directions and collide directly. Immediately before the collision the speed of A is 5 m s^{-1} and the speed of B is 3 m s^{-1} . In the collision, the magnitude of the impulse exerted by B on A is 3.6 N s . As a result of the collision the direction of motion of A is reversed.

(a) Find the speed of A immediately after the collision.

(3)

The speed of B immediately after the collision is 1 m s^{-1} .

(b) Find the two possible values of m .

(4)

3.

Figure 1



A uniform rod AB has length 100 cm. Two light pans are suspended, one from each end of the rod, by two strings which are assumed to be light and inextensible. The system forms a balance with the rod resting horizontally on a smooth pivot, as shown in Fig. 1.

A particle of weight 16 N is placed in the pan at A and a particle of weight 5 N is placed in the pan at B . The rod rests horizontally in equilibrium when the pivot is at the point C on the rod, where $AC = 30$ cm.

(a) Find the weight of the rod. (3)

The particle in the pan at A is replaced by a particle of weight 3.5 N. The particle of weight 5 N remains in the pan at B . The rod now rests horizontally in equilibrium when the pivot is moved to the point D .

(b) Find the distance AD . (4)

(c) Explain briefly where the assumption that the strings are light has been used in your answer to part (a). (1)

Turn over

4.

Figure 2

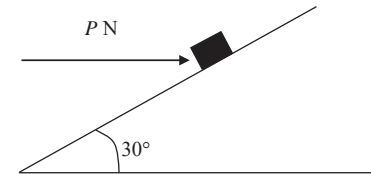

A box of mass 6 kg lies on a rough plane inclined at an angle of 30° to the horizontal. The box is held in equilibrium by means of a horizontal force of magnitude P newtons, as shown in Fig. 2. The line of action of the force is in the same vertical plane as a line of greatest slope of the plane. The coefficient of friction between the box and the plane is 0.4. The box is modelled as a particle.

Given that the box is in limiting equilibrium and on the point of moving up the plane, find,

(a) the normal reaction exerted on the box by the plane, (4)

(b) the value of P . (3)

The horizontal force is removed.

(c) Show that the box will now start to move down the plane. (5)

5. A particle P of mass 2 kg moves in a plane under the action of a single constant force \mathbf{F} newtons. At time t seconds, the velocity of P is \mathbf{v} m s⁻¹. When $t = 0$, $\mathbf{v} = (-5\mathbf{i} + 7\mathbf{j})$ and when $t = 3$, $\mathbf{v} = (\mathbf{i} - 2\mathbf{j})$.

(a) Find in degrees the angle between the direction of motion of P when $t = 3$ and the vector \mathbf{j} . (3)

(b) Find the acceleration of P . (2)

(c) Find the magnitude of \mathbf{F} . (3)

(d) Find in terms of t the velocity of P . (2)

(e) Find the time at which P is moving parallel to the vector $\mathbf{i} + \mathbf{j}$. (3)

6. A man travels in a lift to the top of a tall office block. The lift starts from rest on the ground floor and moves vertically. It comes to rest again at the top floor, having moved a vertical distance of 27 m. The lift initially accelerates with a constant acceleration of 2 m s^{-1} until it reaches a speed of 3 m s^{-1} . It then moves with a constant speed of 3 m s^{-1} for T seconds. Finally it decelerates with a constant deceleration for 2.5 s before coming to rest at the top floor.

- (a) Sketch a speed-time graph for the motion of the lift. (2)
- (b) Hence, or otherwise, find the value of T . (3)
- (c) Sketch an acceleration-time graph for the motion of the lift. (3)

The mass of the man is 80 kg and the mass of the lift is 120 kg. The lift is pulled up by means of a vertical cable attached to the top of the lift. By modelling the cable as light and inextensible, find

- (d) the tension in the cable when the lift is accelerating, (3)
- (e) the magnitude of the force exerted by the lift on the man during the last 2.5 s of the motion. (3)

TURN OVER FOR QUESTION 7

Turn over

7.

Figure 3

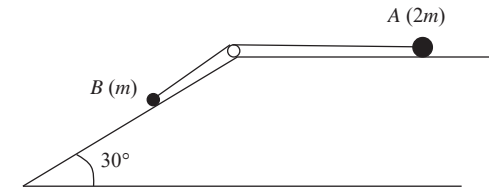

Particles A and B , of mass $2m$ and m respectively, are attached to the ends of a light inextensible string. The string passes over a small smooth pulley fixed at the edge of a rough horizontal table. Particle A is held on the table, while B rests on a smooth plane inclined at 30° to the horizontal, as shown in Fig. 3. The string is in the same vertical plane as a line of greatest slope of the inclined plane. The coefficient of friction between A and the table is μ . The particle A is released from rest and begins to move.

By writing down an equation of motion for each particle,

- (a) show that, while both particles move with the string taut. Each particle has an acceleration of magnitude $\frac{1}{6}(1 - 4\mu)g$. (7)

When each particle has moved a distance h , the string breaks. The particle A comes to rest before reaching the pulley. Given that $\mu = 0.2$,

- (b) find, in terms of h , the total distance moved by A . (6)

For the model described above,

- (c) state two physical factors, **apart** from air resistance, which could be taken into account to make the model more realistic. (2)

END

Paper Reference(s)

6677**Edexcel GCE****Mechanics M1****(New Syllabus)****Advanced/Advanced Subsidiary****Tuesday 5 November 2002 – Morning****Time: 1 hour 30 minutes****Materials required for examination**

Answer Book (AB16)

Mathematical Formulae (Lilac)

Graph Paper (ASG2)

Items included with question papers

Nil

Candidates may use any calculator EXCEPT those with the facility for symbolic algebra, differentiation and/or integration. Thus candidates may NOT use calculators such as the Texas Instruments TI 89, TI 92, Casio CFX 9970G, Hewlett Packard HP 48G.

Instructions to Candidates

In the boxes on the answer book, write the name of the examining body (Edexcel), your centre number, candidate number, the unit title (Mechanics M1), the paper reference (6677), your surname, other name and signature.

Whenever a numerical value of g is required, take $g = 9.8 \text{ m s}^{-2}$.

When a calculator is used, the answer should be given to an appropriate degree of accuracy.

Information for Candidates

A booklet 'Mathematical Formulae and Statistical Tables' is provided.

Full marks may be obtained for answers to ALL questions.

This paper has eight questions. Pages 7 and 8 are blank.

Advice to Candidates

You must ensure that your answers to parts of questions are clearly labelled.

You must show sufficient working to make your methods clear to the Examiner. Answers without working may gain no credit.

N13536RA

This publication may only be reproduced in accordance with Edexcel copyright policy.
Edexcel Foundation is a registered charity. ©2002 Edexcel

1.

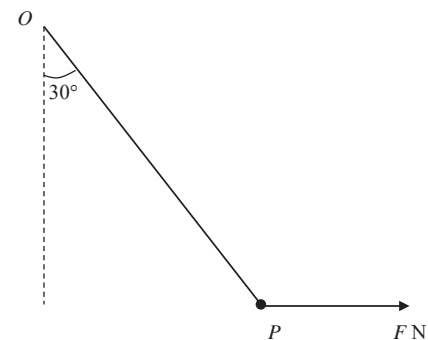
Figure 1

A particle P of weight 6 N is attached to one end of a light inextensible string. The other end of the string is attached to a fixed point O . A horizontal force of magnitude F newtons is applied to P . The particle P is in equilibrium under gravity with the string making an angle of 30° with the vertical, as shown in Fig. 1. Find, to 3 significant figures,

(a) the tension in the string, (3)

(b) the value of F . (3)

2. A particle P of mass 1.5 kg is moving under the action of a constant force $(3\mathbf{i} - 7.5\mathbf{j}) \text{ N}$. Initially P has velocity $(2\mathbf{i} + 3\mathbf{j}) \text{ m s}^{-1}$. Find

(a) the magnitude of the acceleration of P , (4)

(b) the velocity of P , in terms of \mathbf{i} and \mathbf{j} , when P has been moving for 4 seconds. (3)

N13536RA

3. A car accelerates uniformly from rest to a speed of 20 m s^{-1} in T seconds. The car then travels at a constant speed of 20 m s^{-1} for $4T$ seconds and finally decelerates uniformly to rest in a further 50 s .

(a) Sketch a speed-time graph to show the motion of the car. (2)

The total distance travelled by the car is 1220 m . Find

(b) the value of T , (3)

(c) the initial acceleration of the car. (2)

4. Figure 2

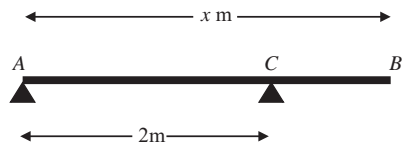

A uniform plank AB has weight 80 N and length x metres. The plank rests in equilibrium horizontally on two smooth supports at A and C , where $AC = 2 \text{ m}$, as shown in Fig. 2. A rock of weight 20 N is placed at B and the plank remains in equilibrium. The reaction on the plank at C has magnitude 90 N . The plank is modelled as a rod and the rock as a particle.

(a) Find the value of x . (4)

(b) State how you have used the model of the rock as a particle. (1)

The support at A is now moved to a point D on the plank and the plank remains in equilibrium with the rock at B . The reaction on the plank at C is now three times the reaction at D .

(c) Find the distance AD . (4)

Turn over

- 5.

Figure 3

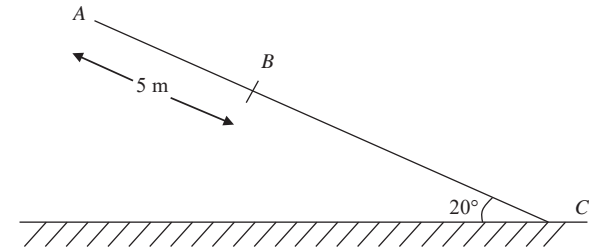

A suitcase of mass 10 kg slides down a ramp which is inclined at an angle of 20° to the horizontal. The suitcase is modelled as a particle and the ramp as a rough plane. The top of the plane is A . The bottom of the plane is C and AC is a line of greatest slope, as shown in Fig. 3. The point B is on AC with $AB = 5 \text{ m}$. The suitcase leaves A with a speed of 10 m s^{-1} and passes B with a speed of 8 m s^{-1} . Find

(a) the deceleration of the suitcase, (2)

(b) the coefficient of friction between the suitcase and the ramp. (6)

The suitcase reaches the bottom of the ramp.

(c) Find the greatest possible length of AC . (2)

6. A railway truck P of mass 1500 kg is moving on a straight horizontal track. The truck P collides with a truck Q of 2500 kg at a point A . Immediately before the collision, P and Q are moving in the same direction with speeds 10 m s^{-1} and 5 m s^{-1} respectively. Immediately after the collision, the direction of motion of P is unchanged and its speed is 4 m s^{-1} . By modelling the trucks as particles,

(a) show that the speed of Q immediately after the collision is 8.6 m s^{-1} . (3)

After the collision at A , the truck P is acted upon by a constant braking force of magnitude 500 N . The truck P comes to rest at the point B .

(b) Find the distance AB . (3)

After the collision Q continues to move with constant speed 8.6 m s^{-1} .

(c) Find the distance between P and Q at the instant when P comes to rest. (5)

7. Two helicopters P and Q are moving in the same horizontal plane. They are modelled as particles moving in straight lines with constant speeds. At noon P is at the point with position vector $(20\mathbf{i} + 35\mathbf{j}) \text{ km}$ with respect to a fixed origin O . At time t hours after noon the position vector of P is $\mathbf{p} \text{ km}$. When $t = \frac{1}{2}$ the position vector of P is $(50\mathbf{i} - 25\mathbf{j}) \text{ km}$. Find

(a) the velocity of P in the form $(a\mathbf{i} + b\mathbf{j}) \text{ km h}^{-1}$, (2)

(b) an expression for \mathbf{p} in terms of t . (2)

At noon Q is at O and at time t hours after noon the position vector of Q is $\mathbf{q} \text{ km}$. The velocity of Q has magnitude 120 km h^{-1} in the direction of $4\mathbf{i} - 3\mathbf{j}$. Find

(d) an expression for \mathbf{q} in terms of t , (3)

(e) the distance, to the nearest km, between P and Q when $t = 2$. (4)

Turn over

8.

Figure 4

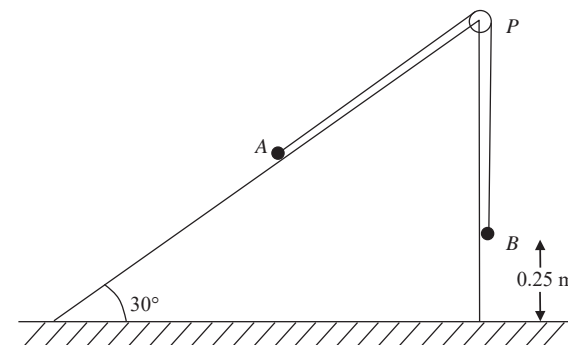

Two particles A and B , of mass $m \text{ kg}$ and 3 kg respectively, are connected by a light inextensible string. The particle A is held resting on a smooth fixed plane inclined at 30° to the horizontal. The string passes over a smooth pulley P fixed at the top of the plane. The portion AP of the string lies along a line of greatest slope of the plane and B hangs freely from the pulley, as shown in Fig. 4. The system is released from rest with B at a height of 0.25 m above horizontal ground. Immediately after release, B descends with an acceleration of $\frac{2}{5}g$. Given that A does not reach P , calculate

(a) the tension in the string while B is descending, (3)

(b) the value of m . (4)

The particle B strikes the ground and does not rebound. Find

(c) the magnitude of the impulse exerted by B on the ground, (3)

(d) the time between the instant when B strikes the ground and the instant when A reaches its highest point. (4)

END

Paper Reference(s)

6677**Edexcel GCE****Mechanics M1****Advanced/Advanced Subsidiary****Monday 13 January 2003 – Afternoon****Time: 1 hour 30 minutes****Materials required for examination**Answer Book (AB16)
Mathematical Formulae (Lilac)
Graph Paper (ASG2)**Items included with question papers**

Nil

Candidates may use any calculator EXCEPT those with the facility for symbolic algebra, differentiation and/or integration. Thus candidates may NOT use calculators such as the Texas Instruments TI 89, TI 92, Casio CFX 9970G, Hewlett Packard HP 48G.

Instructions to Candidates

In the boxes on the answer book, write the name of the examining body (Edexcel), your centre number, candidate number, the unit title (Mechanics M1), the paper reference (6677), your surname, other name and signature.

Whenever a numerical value of g is required, take $g = 9.8 \text{ m s}^{-2}$.

When a calculator is used, the answer should be given to an appropriate degree of accuracy.

Information for Candidates

A booklet 'Mathematical Formulae and Statistical Tables' is provided.

Full marks may be obtained for answers to ALL questions.

This paper has eight questions. Pages 6, 7 and 8 are blank.

Advice to Candidates

You must ensure that your answers to parts of questions are clearly labelled.

You must show sufficient working to make your methods clear to the Examiner. Answers without working may gain no credit.

N10607A

This publication may only be reproduced in accordance with Edexcel copyright policy.
Edexcel Foundation is a registered charity. ©2003 Edexcel

1. A railway truck P of mass 2000 kg is moving along a straight horizontal track with speed 10 m s^{-1} . The truck P collides with a truck Q of mass 3000 kg, which is at rest on the same track. Immediately after the collision Q moves with speed 5 m s^{-1} . Calculate
- (a) the speed of P immediately after the collision, (3)
- (b) the magnitude of the impulse exerted by P on Q during the collision. (2)

2.

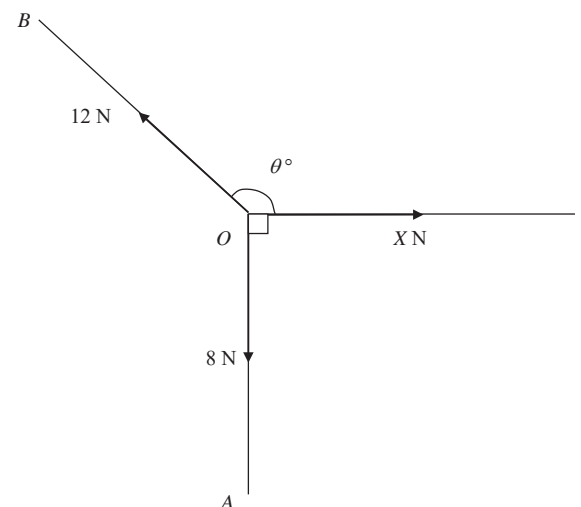
Figure 1

In Fig. 1, $\angle AOC = 90^\circ$ and $\angle BOC = \theta^\circ$. A particle at O is in equilibrium under the action of three coplanar forces. The three forces have magnitude 8 N, 12 N and X N and act along OA , OB and OC respectively. Calculate

- (a) the value, to one decimal place, of θ , (3)
- (b) the value, to 2 decimal places, of X . (3)

3. A particle P of mass 0.4 kg is moving under the action of a constant force \mathbf{F} newtons. Initially the velocity of P is $(6\mathbf{i} - 27\mathbf{j}) \text{ m s}^{-1}$ and 4 s later the velocity of P is $(-14\mathbf{i} + 21\mathbf{j}) \text{ m s}^{-1}$.
- (a) Find, in terms of \mathbf{i} and \mathbf{j} , the acceleration of P . (3)
- (b) Calculate the magnitude of \mathbf{F} . (3)

4. Two ships P and Q are moving along straight lines with constant velocities. Initially P is at a point O and the position vector of Q relative to O is $(6\mathbf{i} + 12\mathbf{j}) \text{ km}$, where \mathbf{i} and \mathbf{j} are unit vectors directed due east and due north respectively. The ship P is moving with velocity $10\mathbf{j} \text{ km h}^{-1}$ and Q is moving with velocity $(-8\mathbf{i} + 6\mathbf{j}) \text{ km h}^{-1}$. At time t hours the position vectors of P and Q relative to O are $\mathbf{p} \text{ km}$ and $\mathbf{q} \text{ km}$ respectively.
- (a) Find \mathbf{p} and \mathbf{q} in terms of t . (3)
- (b) Calculate the distance of Q from P when $t = 3$. (3)
- (c) Calculate the value of t when Q is due north of P . (2)

5.

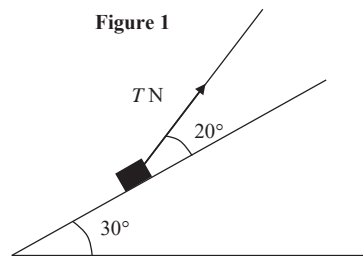

A box of mass 1.5 kg is placed on a plane which is inclined at an angle of 30° to the horizontal. The coefficient of friction between the box and plane is $\frac{1}{3}$. The box is kept in equilibrium by a light string which lies in a vertical plane containing a line of greatest slope of the plane. The string makes an angle of 20° with the plane, as shown in Fig. 2. The box is in limiting equilibrium and is about to move up the plane. The tension in the string is T newtons. The box is modelled as a particle.

Find the value of T . (10)

6.

Figure 3

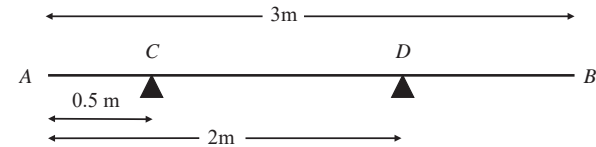

A uniform rod AB has length 3 m and weight 120 N . The rod rests in equilibrium in a horizontal position, smoothly supported at points C and D , where $AC = 0.5 \text{ m}$ and $AD = 2 \text{ m}$, as shown in Fig. 3. A particle of weight W newtons is attached to the rod at a point E where $AE = x$ metres. The rod remains in equilibrium and the magnitude of the reaction at C is now twice the magnitude of the reaction at D .

- (a) Show that $W = \frac{60}{1-x}$. (8)
- (b) Hence deduce the range of possible values of x . (2)

7.

A ball is projected vertically upwards with a speed $u \text{ m s}^{-1}$ from a point A which is 1.5 m above the ground. The ball moves freely under gravity until it reaches the ground. The greatest height attained by the ball is 25.6 m above A .

- (a) Show that $u = 22.4$. (3)

The ball reaches the ground T seconds after it has been projected from A .

- (b) Find, to 2 decimal places, the value of T . (4)

The ground is soft and the ball sinks 2.5 cm into the ground before coming to rest. The mass of the ball is 0.6 kg . The ground is assumed to exert a constant resistive force of magnitude F newtons.

- (c) Find, to 3 significant figures, the value of F . (6)
- (d) State one physical factor which could be taken into account to make the model used in this question more realistic. (1)

8.

Figure 4

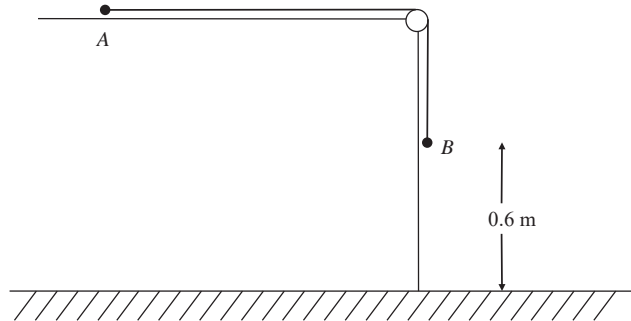

A particle A of mass 0.8 kg rests on a horizontal table and is attached to one end of a light inextensible string. The string passes over a small smooth pulley P fixed at the edge of the table. The other end of the string is attached to a particle B of mass 1.2 kg which hangs freely below the pulley, as shown in Fig. 4. The system is released from rest with the string taut and with B at a height of 0.6 m above the ground. In the subsequent motion A does not reach P before B reaches the ground. In an initial model of the situation, the table is assumed to be smooth. Using this model, find

- (a) the tension in the string before B reaches the ground, (5)
 (b) the time taken by B to reach the ground. (3)

In a refinement of the model, it is assumed that the table is rough and that the coefficient of friction between A and the table is $\frac{1}{5}$. Using this refined model,

- (c) find the time taken by B to reach the ground. (8)

END

Paper Reference(s)

6677**Edexcel GCE****Mechanics M1****Advanced/Advanced Subsidiary****Monday 19 May 2003 – Morning****Time: 1 hour 30 minutes****Materials required for examination papers**

Answer Book (AB16)
 Mathematical Formulae (Lilac)
 Graph Paper (ASG2)

Items included with question

Nil

Candidates may use any calculator EXCEPT those with the facility for symbolic algebra, differentiation and/or integration. Thus candidates may NOT use calculators such as the Texas Instruments TI 89, TI 92, Casio CFX 9970G, Hewlett Packard HP 48G.

Instructions to Candidates

In the boxes on the answer book, write the name of the examining body (Edexcel), your centre number, candidate number, the unit title (Mechanics M1), the paper reference (6677), your surname, other name and signature.

Whenever a numerical value of g is required, take $g = 9.8 \text{ m s}^{-2}$.

When a calculator is used, the answer should be given to an appropriate degree of accuracy.

Information for Candidates

A booklet 'Mathematical Formulae and Statistical Tables' is provided.

Full marks may be obtained for answers to ALL questions.

This paper has eight questions.

Advice to Candidates

You must ensure that your answers to parts of questions are clearly labelled.

You must show sufficient working to make your methods clear to the Examiner. Answers without working may gain no credit.

1.

Figure 1

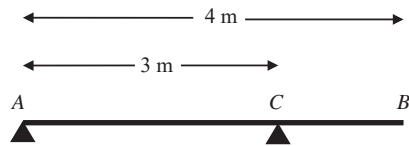

A uniform plank AB has mass 40 kg and length 4 m. It is supported in a horizontal position by two smooth pivots, one at the end A , the other at the point C of the plank where $AC = 3$ m, as shown in Fig. 1. A man of mass 80 kg stands on the plank which remains in equilibrium. The magnitudes of the reactions at the two pivots are each equal to R newtons. By modelling the plank as a rod and the man as a particle, find

- (a) the value of R , (2)
- (b) the distance of the man from A . (4)
-

2. Two particles A and B have mass 0.12 kg and 0.08 kg respectively. They are initially at rest on a smooth horizontal table. Particle A is then given an impulse in the direction AB so that it moves with speed 3 m s^{-1} directly towards B .

- (a) Find the magnitude of this impulse, stating clearly the units in which your answer is given. (2)

Immediately after the particles collide, the speed of A is 1.2 m s^{-1} , its direction of motion being unchanged.

- (b) Find the speed of B immediately after the collision. (3)
- (c) Find the magnitude of the impulse exerted on A in the collision. (2)
-

3. A competitor makes a dive from a high springboard into a diving pool. She leaves the springboard vertically with a speed of 4 m s^{-1} upwards. When she leaves the springboard, she is 5 m above the surface of the pool. The diver is modelled as a particle moving vertically under gravity alone and it is assumed that she does not hit the springboard as she descends. Find

- (a) her speed when she reaches the surface of the pool, (3)
- (b) the time taken to reach the surface of the pool. (3)
- (c) State two physical factors which have been ignored in the model. (2)
-

4.

Figure 2

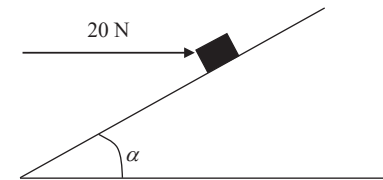

A parcel of mass 5 kg lies on a rough plane inclined at an angle α to the horizontal, where $\tan \alpha = \frac{3}{4}$. The parcel is held in equilibrium by the action of a horizontal force of magnitude 20 N, as shown in Fig. 2. The force acts in a vertical plane through a line of greatest slope of the plane. The parcel is on the point of sliding down the plane. Find the coefficient of friction between the parcel and the plane.

(8)

5. A particle P moves with constant acceleration $(2\mathbf{i} - 3\mathbf{j}) \text{ m s}^{-2}$. At time t seconds, its velocity is $\mathbf{v} \text{ m s}^{-1}$. When $t = 0$, $\mathbf{v} = -2\mathbf{i} + 7\mathbf{j}$.

- (a) Find the value of t when P is moving parallel to the vector \mathbf{i} . (4)
- (b) Find the speed of P when $t = 3$. (3)
- (c) Find the angle between the vector \mathbf{j} and the direction of motion of P when $t = 3$. (3)
-

6. A particle P of mass 3 kg is projected up a line of greatest slope of a rough plane inclined at an angle of 30° to the horizontal. The coefficient of friction between P and the plane is 0.4. The initial speed of P is 6 m s^{-1} . Find

- (a) the frictional force acting on P as it moves up the plane, (4)
- (b) the distance moved by P up the plane before P comes to instantaneous rest. (7)

7. Two trains A and B run on parallel straight tracks. Initially both are at rest in a station and level with each other. At time $t = 0$, A starts to move. It moves with constant acceleration for 12 s up to a speed of 30 m s^{-1} , and then moves at a constant speed of 30 m s^{-1} . Train B starts to move in the same direction as A when $t = 40$, where t is measured in seconds. It accelerates with the same initial acceleration as A , up to a speed of 60 m s^{-1} . It then moves at a constant speed of 60 m s^{-1} . Train B overtakes A after both trains have reached their maximum speed. Train B overtakes A when $t = T$.

- (a) Sketch, on the same diagram, the speed-time graphs of both trains for $0 \leq t \leq T$. (3)
- (b) Find the value of T . (9)

8. A car which has run out of petrol is being towed by a breakdown truck along a straight horizontal road. The truck has mass 1200 kg and the car has mass 800 kg. The truck is connected to the car by a horizontal rope which is modelled as light and inextensible. The truck's engine provides a constant driving force of 2400 N. The resistances to motion of the truck and the car are modelled as constant and of magnitude 600 N and 400 N respectively. Find

- (a) the acceleration of the truck and the car, (3)
- (b) the tension in the rope. (3)

When the truck and car are moving at 20 m s^{-1} , the rope breaks. The engine of the truck provides the same driving force as before. The magnitude of the resistance to the motion of the truck remains 600 N.

- (c) Show that the truck reaches a speed of 28 m s^{-1} approximately 6 s earlier than it would have done if the rope had not broken. (7)

END

Paper Reference(s)

6677

Edexcel GCE

Mechanics M1

Advanced/Advanced Subsidiary

Tuesday 4 November 2003 – Morning

Time: 1 hour 30 minutes

Materials required for examination

Answer Book (AB16)
Mathematical Formulae (Lilac)
Graph Paper (ASG2)

Items included with question papers

Nil

Candidates may use any calculator EXCEPT those with the facility for symbolic algebra, differentiation and/or integration. Thus candidates may NOT use calculators such as the Texas Instruments TI 89, TI 92, Casio CFX 9970G, Hewlett Packard HP 48G.

Instructions to Candidates

In the boxes on the answer book, write the name of the examining body (Edexcel), your centre number, candidate number, the unit title (Mechanics M1), the paper reference (6677), your surname, other name and signature.

Whenever a numerical value of g is required, take $g = 9.8 \text{ m s}^{-2}$.

When a calculator is used, the answer should be given to an appropriate degree of accuracy.

Information for Candidates

A booklet 'Mathematical Formulae and Statistical Tables' is provided.

Full marks may be obtained for answers to ALL questions.

This paper has seven questions.

Advice to Candidates

You must ensure that your answers to parts of questions are clearly labelled.

You must show sufficient working to make your methods clear to the Examiner. Answers without working may gain no credit.

N16610A

This publication may only be reproduced in accordance with Edexcel copyright policy. Edexcel Foundation is a registered charity. ©2003 Edexcel

1. A small ball is projected vertically upwards from a point A . The greatest height reached by the ball is 40 m above A . Calculate

(a) the speed of projection, (3)

(b) the time between the instant that the ball is projected and the instant it returns to A . (3)

2. A railway truck S of mass 2000 kg is travelling due east along a straight horizontal track with constant speed 12 m s^{-1} . The truck S collides with a truck T which is travelling due west along the same track as S with constant speed 6 m s^{-1} . The magnitude of the impulse of T on S is 28800 Ns.

(a) Calculate the speed of S immediately after the collision. (3)

(b) State the direction of motion of S immediately after the collision. (1)

Given that, immediately after the collision, the speed of T is 3.6 m s^{-1} , and that T and S are moving in opposite directions,

(c) calculate the mass of T . (4)

3. **Figure 1**

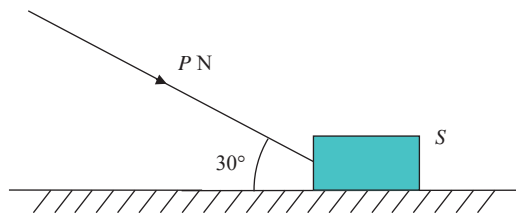

A heavy suitcase S of mass 50 kg is moving along a horizontal floor under the action of a force of magnitude P newtons. The force acts at 30° to the floor, as shown in Fig. 1, and S moves in a straight line at constant speed. The suitcase is modelled as a particle and the floor as a rough horizontal plane. The coefficient of friction between S and the floor is $\frac{3}{5}$.

Calculate the value of P . (9)

4. A car starts from rest at a point S on a straight racetrack. The car moves with constant acceleration for 20 s, reaching a speed of 25 m s^{-1} . The car then travels at a constant speed of 25 m s^{-1} for 120 s. Finally it moves with constant deceleration, coming to rest at a point F .

(a) In the space below, sketch a speed-time graph to illustrate the motion of the car. (2)

The distance between S and F is 4 km.

(b) Calculate the total time the car takes to travel from S to F . (3)

A motorcycle starts at S , 10 s after the car has left S . The motorcycle moves with constant acceleration from rest and passes the car at a point P which is 1.5 km from S . When the motorcycle passes the car, the motorcycle is still accelerating and the car is moving at a constant speed. Calculate

(c) the time the motorcycle takes to travel from S to P , (5)

(d) the speed of the motorcycle at P . (2)

5. A particle P of mass 3 kg is moving under the action of a constant force \mathbf{F} newtons. At $t = 0$, P has velocity $(3\mathbf{i} - 5\mathbf{j}) \text{ m s}^{-1}$. At $t = 4 \text{ s}$, the velocity of P is $(-5\mathbf{i} + 11\mathbf{j}) \text{ m s}^{-1}$. Find

(a) the acceleration of P , in terms of \mathbf{i} and \mathbf{j} . (2)

(b) the magnitude of \mathbf{F} . (4)

At $t = 6 \text{ s}$, P is at the point A with position vector $(6\mathbf{i} - 29\mathbf{j}) \text{ m}$ relative to a fixed origin O . At this instant the force \mathbf{F} newtons is removed and P then moves with constant velocity. Three seconds after the force has been removed, P is at the point B .

(c) Calculate the distance of B from O . (6)

6.

Figure 2

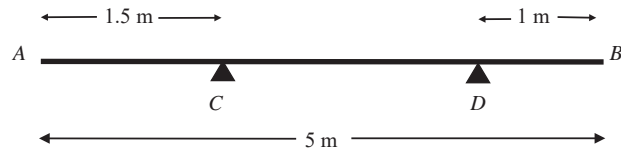

A non-uniform rod AB has length 5 m and weight 200 N. The rod rests horizontally in equilibrium on two smooth supports C and D , where $AC = 1.5$ m and $DB = 1$ m, as shown in Fig. 2. The centre of mass of AB is x metres from A . A particle of weight W newtons is placed on the rod at A . The rod remains in equilibrium and the magnitude of the reaction of C on the rod is 160 N.

(a) Show that $50x - W = 100$.

(5)

The particle is now removed from A and placed on the rod at B . The rod remains in equilibrium and the reaction of C on the rod now has magnitude 50 N.

(b) Obtain another equation connecting W and x .

(3)

(c) Calculate the value of x and the value of W .

(4)

7.

Figure 3

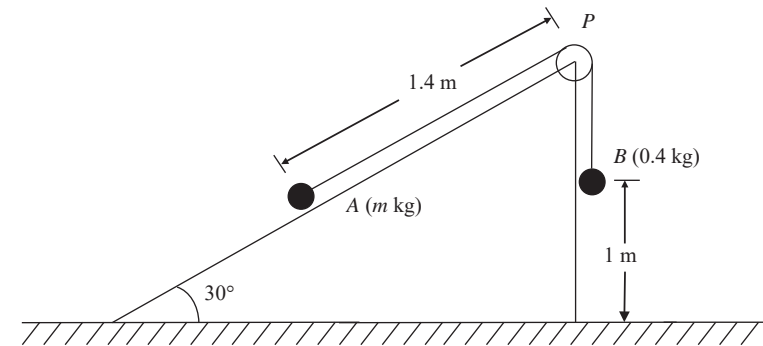

Figure 3 shows two particles A and B , of mass m kg and 0.4 kg respectively, connected by a light inextensible string. Initially A is held at rest on a fixed smooth plane inclined at 30° to the horizontal. The string passes over a small light smooth pulley P fixed at the top of the plane. The section of the string from A to P is parallel to a line of greatest slope of the plane. The particle B hangs freely below P . The system is released from rest with the string taut and B descends with acceleration $\frac{1}{5}g$.

(a) Write down an equation of motion for B .

(2)

(b) Find the tension in the string.

(2)

(c) Prove that $m = \frac{16}{35}$.

(4)

(d) State where in the calculations you have used the information that P is a light smooth pulley.

(1)

On release, B is at a height of one metre above the ground and $AP = 1.4$ m. The particle B strikes the ground and does not rebound.

(e) Calculate the speed of B as it reaches the ground.

(2)

(f) Show that A comes to rest as it reaches P .

(5)

END

Paper Reference(s)

6677

Edexcel GCE**Mechanics M1****Advanced/Advanced Subsidiary****Monday 12 January 2004 – Afternoon****Time: 1 hour 30 minutes****Materials required for examination**

Answer Book (AB16)

Mathematical Formulae (Lilac)

Graph Paper (ASG2)

Items included with question papers

Nil

Candidates may use any calculator EXCEPT those with the facility for symbolic algebra, differentiation and/or integration. Thus candidates may NOT use calculators such as the Texas Instruments TI 89, TI 92, Casio CFX 9970G, Hewlett Packard HP 48G.

Instructions to Candidates

In the boxes on the answer book, write the name of the examining body (Edexcel), your centre number, candidate number, the unit title (Mechanics M1), the paper reference (6677), your surname, other name and signature.

Whenever a numerical value of g is required, take $g = 9.8 \text{ m s}^{-2}$.

When a calculator is used, the answer should be given to an appropriate degree of accuracy.

Information for Candidates

A booklet 'Mathematical Formulae and Statistical Tables' is provided.

Full marks may be obtained for answers to ALL questions.

This paper has seven questions.

Advice to Candidates

You must ensure that your answers to parts of questions are clearly labelled.

You must show sufficient working to make your methods clear to the Examiner. Answers without working may gain no credit.

N16614A

This publication may only be reproduced in accordance with London Qualifications Limited copyright policy.
©2004 London Qualifications Limited

1. Two trucks A and B , moving in opposite directions on the same horizontal railway track, collide. The mass of A is 600 kg . The mass of B is $m \text{ kg}$. Immediately before the collision, the speed of A is 4 m s^{-1} and the speed of B is 2 m s^{-1} . Immediately after the collision, the trucks are joined together and move with the same speed 0.5 m s^{-1} . The direction of motion of A is unchanged by the collision. Find

(a) the value of m , (4)

(b) the magnitude of the impulse exerted on A in the collision. (3)

2.

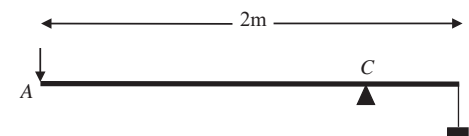
Figure 1

A lever consists of a uniform steel rod AB , of weight 100 N and length 2 m , which rests on a small smooth pivot at a point C of the rod. A load of weight 2200 N is suspended from the end B of the rod by a rope. The lever is held in equilibrium in a horizontal position by a vertical force applied at the end A , as shown in Fig. 1. The rope is modelled as a light string.

Given that $BC = 0.2 \text{ m}$,

(a) find the magnitude of the force applied at A . (4)

The position of the pivot is changed so that the rod remains in equilibrium when the force at A has magnitude 120 N .

(b) Find, to the nearest cm, the new distance of the pivot from B . (5)

3. The tile on a roof becomes loose and slides from rest down the roof. The roof is modelled as a plane surface inclined at 30° to the horizontal. The coefficient of friction between the tile and the roof is 0.4. The tile is modelled as a particle of mass m kg.

(a) Find the acceleration of the tile as it slides down the roof. (7)

The tile moves a distance 3 m before reaching the edge of the roof.

(b) Find the speed of the tile as it reaches the edge of the roof. (2)

(c) Write down the answer to part (a) if the tile had mass $2m$ kg. (1)

4. Figure 2

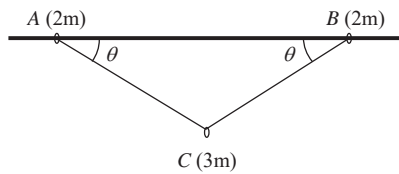

Two small rings, A and B , each of mass $2m$, are threaded on a rough horizontal pole. The coefficient of friction between each ring and the pole is μ . The rings are attached to the ends of a light inextensible string. A smooth ring C , of mass $3m$, is threaded on the string and hangs in equilibrium below the pole. The rings A and B are in limiting equilibrium on the pole, with $\angle BAC = \angle ABC = \theta$, where $\tan \theta = \frac{3}{4}$, as shown in Fig. 2.

(a) Show that the tension in the string is $\frac{5}{2}mg$. (3)

(b) Find the value of μ . (7)

5. Figure 3

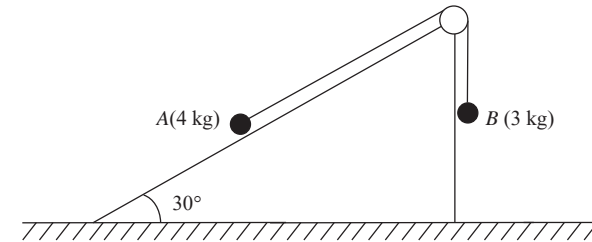

A particle A of mass 4 kg moves on the inclined face of a smooth wedge. This face is inclined at 30° to the horizontal. The wedge is fixed on horizontal ground. Particle A is connected to a particle B , of mass 3 kg, by a light inextensible string. The string passes over a small light smooth pulley which is fixed at the top of the plane. The section of the string from A to the pulley lies in a line of greatest slope of the wedge. The particle B hangs freely below the pulley, as shown in Fig. 3. The system is released from rest with the string taut. For the motion before A reaches the pulley and before B hits the ground, find

(a) the tension in the string, (6)

(b) the magnitude of the resultant force exerted by the string on the pulley. (3)

(c) The string in this question is described as being 'light'.

- (i) Write down what you understand by this description.
- (ii) State how you have used the fact that the string is light in your answer to part (a). (2)

6. A train starts from rest at a station A and moves along a straight horizontal track. For the first 10 s, the train moves with constant acceleration 1.2 m s^{-2} . For the next 24 s it moves at a constant acceleration 0.75 m s^{-2} . It then moves with constant speed for T seconds. Finally it slows down with constant deceleration 3 m s^{-2} until it comes to a rest at station B .

- (a) Show that, 34 s after leaving A , the speed of the train is 30 m s^{-1} . (3)
- (b) Sketch a speed-time graph to illustrate the motion of the train as it moves from A to B . (3)
- (c) Find the distance moved by the train during the first 34 s of its journey from A . (4)

The distance from A to B is 3 km.

- (d) Find the value of T . (4)
-

7. [In this question the vectors \mathbf{i} and \mathbf{j} are horizontal unit vectors in the direction due east and due north respectively.]

Two boats A and B are moving with constant velocities. Boat A moves with velocity $9\mathbf{j} \text{ km h}^{-1}$. Boat B moves with velocity $(3\mathbf{i} + 5\mathbf{j}) \text{ km h}^{-1}$.

- (a) Find the bearing on which B is moving. (2)

At noon, A is at point O , and B is 10 km due west of O . At time t hours after noon, the position vectors of A and B relative to O are \mathbf{a} km and \mathbf{b} km respectively.

- (b) Find expressions for \mathbf{a} and \mathbf{b} in terms of t , giving your answer in the form $p\mathbf{i} + q\mathbf{j}$. (3)

- (c) Find the time when B is due south of A . (2)

At time t hours after noon, the distance between A and B is d km. By finding an expression for \overline{AB} ,

- (d) show that $d^2 = 25t^2 - 60t + 100$. (4)

At noon, the boats are 10 km apart.

- (e) Find the time after noon at which the boats are again 10 km apart. (3)
-

END

Paper Reference(s)

6677

Edexcel GCE**Mechanics M1****Advanced/Advanced Subsidiary****Monday 24 May 2004 – Morning****Time: 1 hour 30 minutes****Materials required for examination**Answer Book (AB16)
Mathematical Formulae (Lilac)
Graph Paper (ASG2)**Items included with question papers**

Nil

Candidates may use any calculator EXCEPT those with the facility for symbolic algebra, differentiation and/or integration. Thus candidates may NOT use calculators such as the Texas Instruments TI 89, TI 92, Casio CFX 9970G, Hewlett Packard HP 48G.

Instructions to Candidates

In the boxes on the answer book, write the name of the examining body (Edexcel), your centre number, candidate number, the unit title (Mechanics M1), the paper reference (6677), your surname, other name and signature.

Whenever a numerical value of g is required, take $g = 9.8 \text{ m s}^{-2}$.

When a calculator is used, the answer should be given to an appropriate degree of accuracy.

Information for Candidates

A booklet 'Mathematical Formulae and Statistical Tables' is provided.

Full marks may be obtained for answers to ALL questions.

This paper has seven questions.

Advice to Candidates

You must ensure that your answers to parts of questions are clearly labelled.

You must show sufficient working to make your methods clear to the Examiner. Answers without working may gain no credit.

N16617A

This publication may only be reproduced in accordance with London Qualifications Limited copyright policy. ©2004 London Qualifications Limited.

1.

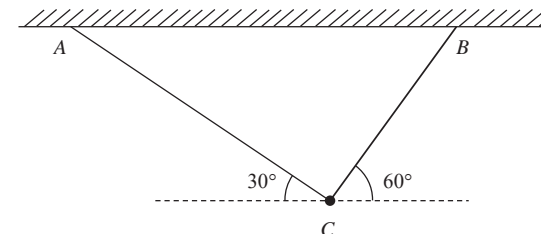
Figure 1

A particle of weight W newtons is attached at C to the ends of two light inextensible strings AC and BC . The other ends of the strings are attached to two fixed points A and B on a horizontal ceiling. The particle hangs in equilibrium with AC and BC inclined to the horizontal at 30° and 60° respectively, as shown in Fig.1. Given the tension in AC is 50 N , calculate

(a) the tension in BC , to 3 significant figures, (3)

(b) the value of W . (3)

2. A particle P is moving with constant acceleration along a straight horizontal line ABC , where $AC = 24 \text{ m}$. Initially P is at A and is moving with speed 5 m s^{-1} in the direction AB . After 1.5 s , the direction of motion of P is unchanged and P is at B with speed 9.5 m s^{-1} .

(a) Show that the speed of P at C is 13 m s^{-1} . (4)

The mass of P is 2 kg . When P reaches C , an impulse of magnitude 30 Ns is applied to P in the direction CB .

(b) Find the velocity of P immediately after the impulse has been applied, stating clearly the direction of motion of P at this instant. (3)

N16617A

2

3. A particle P of mass 2 kg is moving with speed $u\text{ m s}^{-1}$ in a straight line on a smooth horizontal plane. The particle P collides directly with a particle Q of mass 4 kg which is at rest on the same horizontal plane. Immediately after the collision, P and Q are moving in opposite directions and the speed of P is one-third the speed of Q .

(a) Show that the speed of P immediately after the collision is $\frac{1}{3}u\text{ m s}^{-1}$. (4)

After the collision P continues to move in the same straight line and is brought to rest by a constant resistive force of magnitude 10 N . The distance between the point of collision and the point where P comes to rest is 1.6 m .

(b) Calculate the value of u . (5)

4. Figure 2

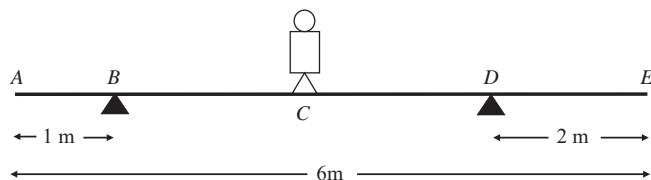

A plank AE , of length 6 m and mass 10 kg , rests in a horizontal position on supports at B and D , where $AB = 1\text{ m}$ and $DE = 2\text{ m}$. A child of mass 20 kg stands at C , the mid-point of BD , as shown in Fig. 2. The child is modelled as a particle and the plank as a uniform rod. The child and the plank are in equilibrium. Calculate

- (a) the magnitude of the force exerted by the support on the plank at B , (4)
 (b) the magnitude of the force exerted by the support on the plank at D . (3)

The child now stands at a point F on the plank. The plank is in equilibrium and on the point of tilting about D .

(c) Calculate the distance DF . (4)

5. Figure 3

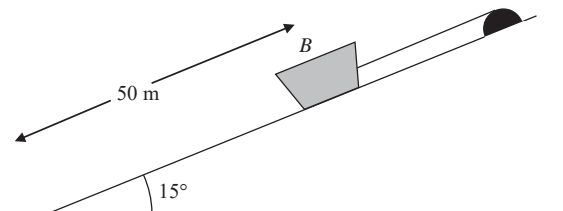

Figure 3 shows a boat B of mass 400 kg held at rest on a slipway by a rope. The boat is modelled as a particle and the slipway as a rough plane inclined at 15° to the horizontal. The coefficient of friction between B and the slipway is 0.2 . The rope is modelled as a light, inextensible string, parallel to a line of greatest slope of the plane. The boat is in equilibrium and on the point of sliding down the slipway.

(a) Calculate the tension in the rope. (6)

The boat is 50 m from the bottom of the slipway. The rope is detached from the boat and the boat slides down the slipway.

(b) Calculate the time taken for the boat to slide to the bottom of the slipway. (6)

6. A small boat S , drifting in the sea, is modelled as a particle moving in a straight line at constant speed. When first sighted at 0900, S is at a point with position vector $(4\mathbf{i} - 6\mathbf{j})\text{ km}$ relative to a fixed origin O , where \mathbf{i} and \mathbf{j} are unit vectors due east and due north respectively. At 0945, S is at the point with position vector $(7\mathbf{i} - 7.5\mathbf{j})\text{ km}$. At time t hours after 0900, S is at the point with position vector $\mathbf{s}\text{ km}$.

- (a) Calculate the bearing on which S is drifting. (4)
 (b) Find an expression for \mathbf{s} in terms of t . (3)

At 1000 a motor boat M leaves O and travels with constant velocity $(p\mathbf{i} + q\mathbf{j})\text{ km h}^{-1}$. Given that M intercepts S at 1015,

(c) calculate the value of p and the value of q . (6)

7.

Figure 4

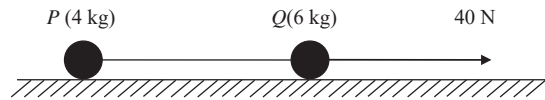

Two particles P and Q , of mass 4 kg and 6 kg respectively, are joined by a light inextensible string. Initially the particles are at rest on a rough horizontal plane with the string taut. The coefficient of friction between each particle and the plane is $\frac{2}{7}$. A constant force of magnitude 40 N is then applied to Q in the direction PQ , as shown in Fig. 4.

- (a) Show that the acceleration of Q is 1.2 m s^{-2} . (4)
- (b) Calculate the tension in the string when the system is moving. (3)
- (c) State how you have used the information that the string is inextensible. (1)

After the particles have been moving for 7 s, the string breaks. The particle Q remains under the action of the force of magnitude 40 N.

- (d) Show that P continues to move for a further 3 seconds. (5)
- (e) Calculate the speed of Q at the instant when P comes to rest. (4)

END

Paper Reference(s)

6677

Edexcel GCE

Mechanics M1

Advanced/Advanced Subsidiary

Tuesday 2 November 2004 – Morning

Time: 1 hour 30 minutes

Materials required for examination

Answer Book (AB16)
Mathematical Formulae (Lilac)
Graph Paper (ASG2)

Items included with question papers

Nil

Candidates may use any calculator EXCEPT those with the facility for symbolic algebra, differentiation and/or integration. Thus candidates may NOT use calculators such as the Texas Instruments TI 89, TI 92, Casio CFX 9970G, Hewlett Packard HP 48G.

Instructions to Candidates

In the boxes on the answer book, write the name of the examining body (Edexcel), your centre number, candidate number, the unit title (Mechanics M1), the paper reference (6677), your surname, other name and signature.

Whenever a numerical value of g is required, take $g = 9.8 \text{ m s}^{-2}$.

When a calculator is used, the answer should be given to an appropriate degree of accuracy.

Information for Candidates

A booklet 'Mathematical Formulae and Statistical Tables' is provided.

Full marks may be obtained for answers to ALL questions.

This paper has eight questions.

Advice to Candidates

You must ensure that your answers to parts of questions are clearly labelled.

You must show sufficient working to make your methods clear to the Examiner. Answers without working may gain no credit.

1. A man is driving a car on a straight horizontal road. He sees a junction S ahead, at which he must stop. When the car is at the point P , 300 m from S , its speed is 30 m s^{-1} . The car continues at this constant speed for 2 s after passing P . The man then applies the brakes so that the car has constant deceleration and comes to rest at S .

- (a) Sketch, in the space below, a speed-time graph to illustrate the motion of the car in moving from P to S . (2)
- (b) Find the time taken by the car to travel from P to S . (3)
-

2.

Figure 1

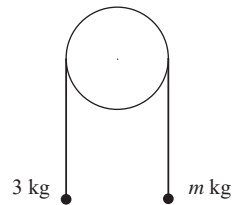

The particles have mass 3 kg and m kg, where $m < 3$. They are attached to the ends of a light inextensible string. The string passes over a smooth fixed pulley. The particles are held in position with the string taut and the hanging parts of the string vertical, as shown in Figure 1. The particles are then released from rest. The initial acceleration of each particle has magnitude $\frac{3}{7}g$. Find

- (a) the tension in the string immediately after the particles are released, (3)
- (b) the value of m . (4)
-

3.

Figure 2

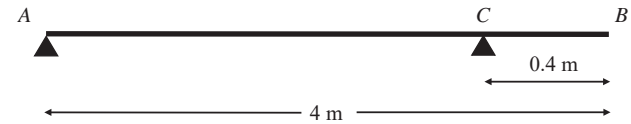

A plank of wood AB has mass 10 kg and length 4 m. It rests in a horizontal position on two smooth supports. One support is at the end A . The other is at the point C , 0.4 m from B , as shown in Figure 2. A girl of mass 30 kg stands at B with the plank in equilibrium. By modelling the plank as a uniform rod and the girl as a particle,

- (a) find the reaction on the plank at A . (4)

The girl gets off the plank. A boulder of mass m kg is placed on the plank at A and a man of mass 80 kg stands on the plank at B . The plank remains in equilibrium and is on the point of tilting about C . By modelling the plank again as a uniform rod, and the man and the boulder as particles,

- (b) find the value of m . (4)
-

4. A tent peg is driven into soft ground by a blow from a hammer. The tent peg has mass 0.2 kg and the hammer has mass 3 kg. The hammer strikes the peg vertically.

Immediately before the impact, the speed of the hammer is 16 m s^{-1} . It is assumed that, immediately after the impact, the hammer and the peg move together vertically downwards.

- (a) Find the common speed of the peg and the hammer immediately after the impact. (3)

Until the peg and hammer come to rest, the resistance exerted by the ground is assumed to be constant and of magnitude R newtons. The hammer and peg are brought to rest 0.05 s after the impact.

- (b) Find, to 3 significant figures, the value of R . (5)
-

5. A particle P moves in a horizontal plane. The acceleration of P is $(-i + 2j) \text{ m s}^{-2}$. At time $t = 0$, the velocity of P is $(2i - 3j) \text{ m s}^{-1}$.

(a) Find, to the nearest degree, the angle between the vector j and the direction of motion of P when $t = 0$. (3)

At time t seconds, the velocity of P is $v \text{ m s}^{-1}$. Find

(b) an expression for v in terms of t , in the form $ai + bj$, (2)

(c) the speed of P when $t = 3$, (3)

(d) the time when P is moving parallel to i . (2)

6. Two cars A and B are moving in the same direction along a straight horizontal road. At time $t = 0$, they are side by side, passing a point O on the road. Car A travels at a constant speed of 30 m s^{-1} . Car B passes O with a speed of 20 m s^{-1} , and has constant acceleration of 4 m s^{-2} .

Find

(a) the speed of B when it has travelled 78 m from O , (2)

(b) the distance from O of A when B is 78 m from O , (4)

(c) the time when B overtakes A . (5)

7.

Figure 3

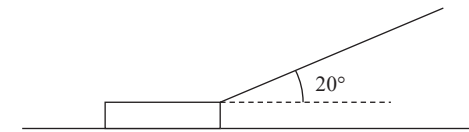

A sledge has mass 30 kg . The sledge is pulled in a straight line along horizontal ground by means of a rope. The rope makes an angle 20° with the horizontal, as shown in Figure 3. The coefficient of friction between the sledge and the ground is 0.2 . The sledge is modelled as a particle and the rope as a light inextensible string. The tension in the rope is 150 N . Find, to 3 significant figures,

(a) the normal reaction of the ground on the sledge, (3)

(b) the acceleration of the sledge. (3)

When the sledge is moving at 12 m s^{-1} , the rope is released from the sledge.

(c) Find, to 3 significant figures, the distance travelled by the sledge from the moment when the rope is released to the moment when the sledge comes to rest. (6)

8.

Figure 4

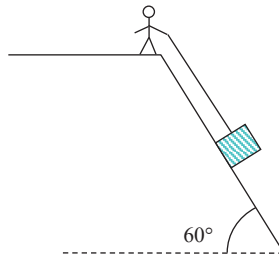

A heavy package is held in equilibrium on a slope by a rope. The package is attached to one end of the rope, the other end being held by a man standing at the top of the slope. The package is modelled as a particle of mass 20 kg. The slope is modelled as a rough plane inclined at 60° to the horizontal and the rope as a light inextensible string. The string is assumed to be parallel to a line of greatest slope of the plane, as shown in Figure 4. At the contact between the package and the slope, the coefficient of friction is 0.4.

- (a) Find the minimum tension in the rope for the package to stay in equilibrium on the slope. (8)

The man now pulls the package up the slope. Given that the package moves at constant speed,

- (b) find the tension in the rope. (4)

- (c) State how you have used, in your answer to part (b), the fact that the package moves
- (i) up the slope,
 - (ii) at constant speed. (2)

END

Paper Reference(s)

6677**Edexcel GCE****Mechanics M1****Advanced Subsidiary****Wednesday 12 January 2005 – Afternoon****Time: 1 hour 30 minutes**Materials required for examination

Mathematical Formulae (Lilac)

Items included with question papers

Nil

Candidates may use any calculator EXCEPT those with the facility for symbolic algebra, differentiation and/or integration. Thus candidates may NOT use calculators such as the Texas Instruments TI 89, TI 92, Casio CFX 9970G, Hewlett Packard HP 48G.

Instructions to Candidates

In the boxes on the answer book, write the name of the examining body (Edexcel), your centre number, candidate number, the unit title (Mechanics M1), the paper reference (6677), your surname, other name and signature.

Whenever a numerical value of g is required, take $g = 9.8 \text{ m s}^{-2}$.

When a calculator is used, the answer should be given to an appropriate degree of accuracy.

Information for Candidates

A booklet 'Mathematical Formulae and Statistical Tables' is provided.

Full marks may be obtained for answers to ALL questions.

This paper has seven questions.

The total mark for this paper is 75.

Advice to Candidates

You must ensure that your answers to parts of questions are clearly labelled.

You must show sufficient working to make your methods clear to the Examiner. Answers without working may gain no credit.

N16740A

This publication may only be reproduced in accordance with London Qualifications Limited copyright policy.
©2005 London Qualifications Limited.

1. A particle P of mass 1.5 kg is moving along a straight horizontal line with speed 3 m s^{-1} . Another particle Q of mass 2.5 kg is moving, in the opposite direction, along the same straight line with speed 4 m s^{-1} . The particles collide. Immediately after the collision the direction of motion of P is reversed and its speed is 2.5 m s^{-1} .

- (a) Calculate the speed of Q immediately after the impact. (3)
- (b) State whether or not the direction of motion of Q is changed by the collision. (1)
- (c) Calculate the magnitude of the impulse exerted by Q on P , giving the units of your answer. (3)
-

2. Figure 1

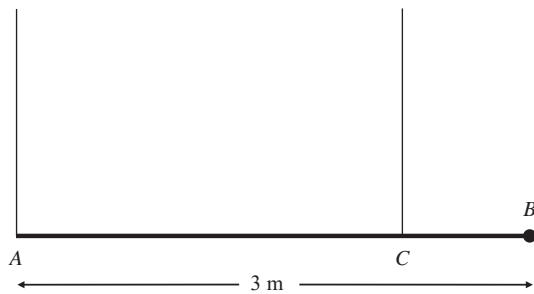

A plank AB has mass 40 kg and length 3 m . A load of mass 20 kg is attached to the plank at B . The loaded plank is held in equilibrium, with AB horizontal, by two vertical ropes attached at A and C , as shown in Figure 1. The plank is modelled as a uniform rod and the load as a particle. Given that the tension in the rope at C is three times the tension in the rope at A , calculate

- (a) the tension in the rope at C , (2)
- (b) the distance CB . (5)
-

- 3.

Figure 2

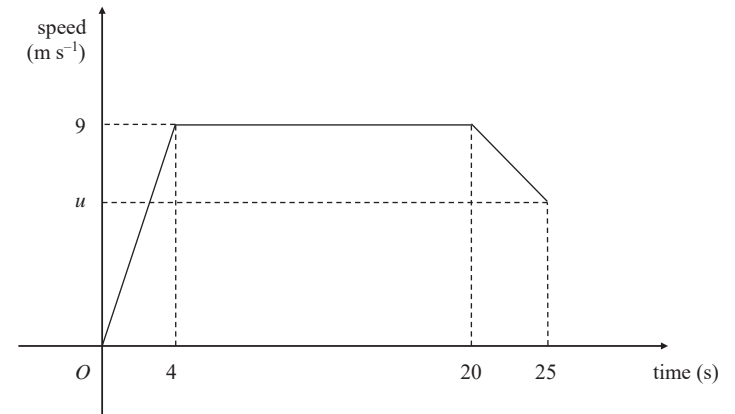

A sprinter runs a race of 200 m . Her total time for running the race is 25 s . Figure 2 is a sketch of the speed-time graph for the motion of the sprinter. She starts from rest and accelerates uniformly to a speed of 9 m s^{-1} in 4 s . The speed of 9 m s^{-1} is maintained for 16 s and she then decelerates uniformly to a speed of $u \text{ m s}^{-1}$ at the end of the race. Calculate

- (a) the distance covered by the sprinter in the first 20 s of the race, (2)
- (b) the value of u , (4)
- (c) the deceleration of the sprinter in the last 5 s of the race. (3)
-

4.

Figure 3

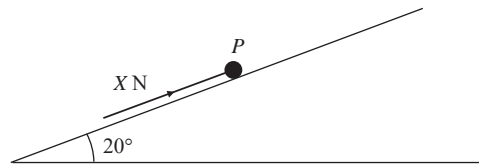

A particle P of mass 2.5 kg rests in equilibrium on a rough plane under the action of a force of magnitude X newtons acting up a line of greatest slope of the plane, as shown in Figure 3. The plane is inclined at 20° to the horizontal. The coefficient of friction between P and the plane is 0.4 . The particle is in limiting equilibrium and is on the point of moving up the plane. Calculate

(a) the normal reaction of the plane on P , (2)

(b) the value of X . (4)

The force of magnitude X newtons is now removed.

(c) Show that P remains in equilibrium on the plane. (4)

5.

Figure 4

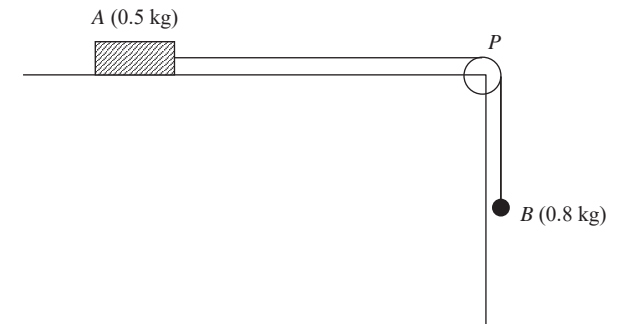

A block of wood A of mass 0.5 kg rests on a rough horizontal table and is attached to one end of a light inextensible string. The string passes over a small smooth pulley P fixed at the edge of the table. The other end of the string is attached to a ball B of mass 0.8 kg which hangs freely below the pulley, as shown in Figure 4. The coefficient of friction between A and the table is μ . The system is released from rest with the string taut. After release, B descends a distance of 0.4 m in 0.5 s. Modelling A and B as particles, calculate

(a) the acceleration of B , (3)

(b) the tension in the string, (4)

(c) the value of μ . (5)

(d) State how in your calculations you have used the information that the string is inextensible. (1)

6. A stone S is sliding on ice. The stone is moving along a straight line ABC , where $AB = 24$ m and $AC = 30$ m. The stone is subject to a constant resistance to motion of magnitude 0.3 N. At A the speed of S is 20 m s^{-1} , and at B the speed of S is 16 m s^{-1} . Calculate

(a) the deceleration of S , (2)

(b) the speed of S at C . (3)

(c) Show that the mass of S is 0.1 kg. (2)

At C , the stone S hits a vertical wall, rebounds from the wall and then slides back along the line CA . The magnitude of the impulse of the wall on S is 2.4 N s and the stone continues to move against a constant resistance of 0.3 N .

(d) Calculate the time between the instant that S rebounds from the wall and the instant that S comes to rest. (6)

7. Two ships P and Q are travelling at night with constant velocities. At midnight, P is at the point with position vector $(20\mathbf{i} + 10\mathbf{j})$ km relative to a fixed origin O . At the same time, Q is at the point with position vector $(14\mathbf{i} - 6\mathbf{j})$ km. Three hours later, P is at the point with position vector $(29\mathbf{i} + 34\mathbf{j})$ km. The ship Q travels with velocity $12\mathbf{j} \text{ km h}^{-1}$. At time t hours after midnight, the position vectors of P and Q are \mathbf{p} km and \mathbf{q} km respectively. Find

(a) the velocity of P , in terms of \mathbf{i} and \mathbf{j} , (2)

(b) expressions for \mathbf{p} and \mathbf{q} , in terms of t , \mathbf{i} and \mathbf{j} . (4)

At time t hours after midnight, the distance between P and Q is d km.

(c) By finding an expression for \overline{PQ} , show that

$$d^2 = 25t^2 - 92t + 292. \quad (5)$$

Weather conditions are such that an observer on P can only see the lights on Q when the distance between P and Q is 15 km or less. Given that when $t = 1$, the lights on Q move into sight of the observer,

(d) find the time, to the nearest minute, at which the lights on Q move out of sight of the observer. (5)

TOTAL FOR PAPER: 75 MARKS

END

Paper Reference(s)

6677

Edexcel GCE

Mechanics M1

Advanced Subsidiary

Tuesday 7 June 2005 – Afternoon

Time: 1 hour 30 minutes

Materials required for examination
Mathematical Formulae (Lilac or Green)

Items included with question papers
Nil

Candidates may use any calculator EXCEPT those with the facility for symbolic algebra, differentiation and/or integration. Thus candidates may NOT use calculators such as the Texas Instruments TI 89, TI 92, Casio CFX 9970G, Hewlett Packard HP 48G.

Instructions to Candidates

In the boxes on the answer book, write the name of the examining body (Edexcel), your centre number, candidate number, the unit title (Mechanics M1), the paper reference (6677), your surname, other name and signature.

Whenever a numerical value of g is required, take $g = 9.8 \text{ m s}^{-2}$.

When a calculator is used, the answer should be given to an appropriate degree of accuracy.

Information for Candidates

A booklet 'Mathematical Formulae and Statistical Tables' is provided.

Full marks may be obtained for answers to ALL questions.

This paper has eight questions.

The total mark for this paper is 75.

Advice to Candidates

You must ensure that your answers to parts of questions are clearly labelled.

You must show sufficient working to make your methods clear to the Examiner. Answers without working may gain no credit.

N20911A

This publication may only be reproduced in accordance with London Qualifications Limited copyright policy.
©2005 London Qualifications Limited.

1. In taking off, an aircraft moves on a straight runway AB of length 1.2 km. The aircraft moves from A with initial speed 2 m s^{-1} . It moves with constant acceleration and 20 s later it leaves the runway at C with speed 74 m s^{-1} . Find

- (a) the acceleration of the aircraft, (2)
 (b) the distance BC . (4)
-

2. Two small steel balls A and B have mass 0.6 kg and 0.2 kg respectively. They are moving towards each other in opposite directions on a smooth horizontal table when they collide directly. Immediately before the collision, the speed of A is 8 m s^{-1} and the speed of B is 2 m s^{-1} . Immediately after the collision, the direction of motion of A is unchanged and the speed of B is twice the speed of A . Find

- (a) the speed of A immediately after the collision, (5)
 (b) the magnitude of the impulse exerted on B in the collision. (3)
-

3. **Figure 1**

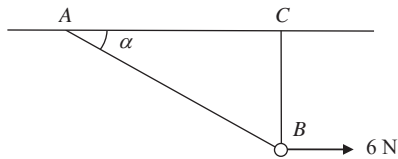

A smooth bead B is threaded on a light inextensible string. The ends of the string are attached to two fixed points A and C on the same horizontal level. The bead is held in equilibrium by a horizontal force of magnitude 6 N acting parallel to AC . The bead B is vertically below C and $\angle BAC = \alpha$, as shown in Figure 1. Given that $\tan \alpha = \frac{3}{4}$, find

- (a) the tension in the string, (3)
 (b) the weight of the bead. (4)
-

- 4.

Figure 2

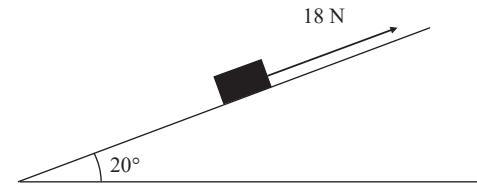

A box of mass 2 kg is pulled up a rough plane face by means of a light rope. The plane is inclined at an angle of 20° to the horizontal, as shown in Figure 2. The rope is parallel to a line of greatest slope of the plane. The tension in the rope is 18 N. The coefficient of friction between the box and the plane is 0.6. By modelling the box as a particle, find

- (a) the normal reaction of the plane on the box, (3)
 (b) the acceleration of the box. (5)
-

5. A train is travelling at 10 m s^{-1} on a straight horizontal track. The driver sees a red signal 135 m ahead and immediately applies the brakes. The train immediately decelerates with constant deceleration for 12 s, reducing its speed to 3 m s^{-1} . The driver then releases the brakes and allows the train to travel at a constant speed of 3 m s^{-1} for a further 15 s. He then applies the brakes again and the train slows down with constant deceleration, coming to rest as it reaches the signal.

- (a) Sketch a speed-time graph to show the motion of the train. (3)
 (b) Find the distance travelled by the train from the moment when the brakes are first applied to the moment when its speed first reaches 3 m s^{-1} . (2)
 (c) Find the total time from the moment when the brakes are first applied to the moment when the train comes to rest. (5)
-

6.

Figure 3

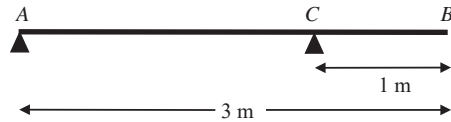

A uniform beam AB has mass 12 kg and length 3 m . The beam rests in equilibrium in a horizontal position, resting on two smooth supports. One support is at end A , the other at a point C on the beam, where $BC = 1\text{ m}$, as shown in Figure 3. The beam is modelled as a uniform rod.

(a) Find the reaction on the beam at C .

(3)

A woman of mass 48 kg stands on the beam at the point D . The beam remains in equilibrium. The reactions on the beam at A and C are now equal.

(b) Find the distance AD .

(7)

7.

Figure 4

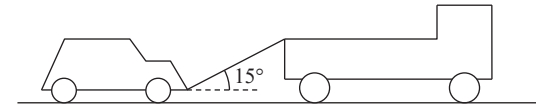

Figure 4 shows a lorry of mass 1600 kg towing a car of mass 900 kg along a straight horizontal road. The two vehicles are joined by a light towbar which is at an angle of 15° to the road. The lorry and the car experience constant resistances to motion of magnitude 600 N and 300 N respectively. The lorry's engine produces a constant horizontal force on the lorry of magnitude 1500 N . Find

(a) the acceleration of the lorry and the car,

(3)

(b) the tension in the towbar.

(4)

When the speed of the vehicles is 6 m s^{-1} , the towbar breaks. Assuming that the resistance to the motion of the car remains of constant magnitude 300 N ,

(c) find the distance moved by the car from the moment the towbar breaks to the moment when the car comes to rest.

(4)

(d) State whether, when the towbar breaks, the normal reaction of the road on the car is increased, decreased or remains constant. Give a reason for your answer.

(2)

8. [In this question, the unit vectors \mathbf{i} and \mathbf{j} are horizontal vectors due east and north respectively.]

At time $t = 0$, a football player kicks a ball from the point A with position vector $(2\mathbf{i} + \mathbf{j})$ m on a horizontal football field. The motion of the ball is modelled as that of a particle moving horizontally with constant velocity $(5\mathbf{i} + 8\mathbf{j})$ m s⁻¹. Find

- (a) the speed of the ball, (2)
- (b) the position vector of the ball after t seconds. (2)

The point B on the field has position vector $(10\mathbf{i} + 7\mathbf{j})$ m.

- (c) Find the time when the ball is due north of B . (2)

At time $t = 0$, another player starts running due north from B and moves with constant speed v m s⁻¹. Given that he intercepts the ball,

- (d) find the value of v . (6)
- (e) State one physical factor, other than air resistance, which would be needed in a refinement of the model of the ball's motion to make the model more realistic. (1)

TOTAL FOR PAPER: 75 MARKS

END

Paper Reference(s)

6677/01

Edexcel GCE

Mechanics M1

Advanced Subsidiary

Thursday 12 January 2006 – Afternoon

Time: 1 hour 30 minutes

Materials required for examination
Mathematical Formulae (Green or Lilac)

Items included with question papers
Nil

Candidates may use any calculator EXCEPT those with the facility for symbolic algebra, differentiation and/or integration. Thus candidates may NOT use calculators such as the Texas Instruments TI 89, TI 92, Casio CFX 9970G, Hewlett Packard HP 48G.

Instructions to Candidates

In the boxes on the answer book, write the name of the examining body (Edexcel), your centre number, candidate number, the unit title (Mechanics M1), the paper reference (6677), your surname, other name and signature.

Whenever a numerical value of g is required, take $g = 9.8$ m s⁻².

When a calculator is used, the answer should be given to an appropriate degree of accuracy.

Information for Candidates

A booklet 'Mathematical Formulae and Statistical Tables' is provided.

Full marks may be obtained for answers to ALL questions.

The marks for individual questions and the parts of questions are shown in round brackets: e.g. (2).

There are 7 questions on this paper. The total mark for this paper is 75.

Advice to Candidates

You must ensure that your answers to parts of questions are clearly labelled.

You must show sufficient working to make your methods clear to the Examiner. Answers without working may gain no credit.

N20875A

This publication may only be reproduced in accordance with Edexcel Limited copyright policy.
©2006 Edexcel Limited.

1. A stone is thrown vertically upwards with speed 16 m s^{-1} from a point h metres above the ground. The stone hits the ground 4 s later. Find

(a) the value of h , (3)

(b) the speed of the stone as it hits the ground. (3)

2. Two particles A and B , of mass 3 kg and 2 kg respectively, are moving in the same direction on a smooth horizontal table when they collide directly. Immediately before the collision, the speed of A is 4 m s^{-1} and the speed of B is 1.5 m s^{-1} . In the collision, the particles join to form a single particle C .

(a) Find the speed of C immediately after the collision. (3)

Two particles P and Q have mass 3 kg and m kg respectively. They are moving towards each other in opposite directions on a smooth horizontal table. Each particle has speed 4 m s^{-1} , when they collide directly. In this collision, the direction of motion of each particle is reversed. The speed of P immediately after the collision is 2 m s^{-1} and the speed of Q is 1 m s^{-1} .

(b) Find (3)

(i) the value of m ,

(ii) the magnitude of the impulse exerted on Q in the collision. (2)

3.

Figure 1

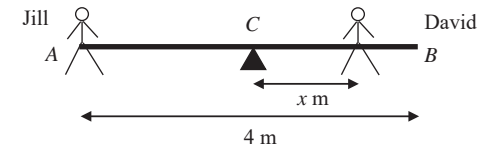

A seesaw in a playground consists of a beam AB of length 4 m which is supported by a smooth pivot at its centre C . Jill has mass 25 kg and sits on the end A . David has mass 40 kg and sits at a distance x metres from C , as shown in Figure 1. The beam is initially modelled as a uniform rod. Using this model,

(a) find the value of x for which the seesaw can rest in equilibrium in a horizontal position. (3)

(b) State what is implied by the modelling assumption that the beam is uniform. (1)

David realises that the beam is not uniform as he finds he must sit at a distance 1.4 m from C for the seesaw to rest horizontally in equilibrium. The beam is now modelled as a non-uniform rod of mass 15 kg. Using this model,

(c) find the distance of the centre of mass of the beam from C . (4)

4. Two forces \mathbf{P} and \mathbf{Q} act on a particle. The force \mathbf{P} has magnitude 7 N and acts due north. The resultant of \mathbf{P} and \mathbf{Q} is a force of magnitude 10 N acting in a direction with bearing 120° . Find

(i) the magnitude of \mathbf{Q} ,

(ii) the direction of \mathbf{Q} , giving your answer as a bearing. (9)

5.

Figure 2

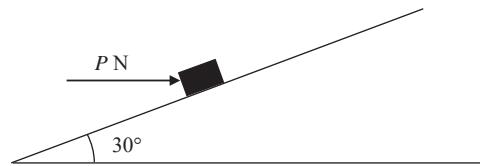

A parcel of weight 10 N lies on a rough plane inclined at an angle of 30° to the horizontal. A horizontal force of magnitude P newtons acts on the parcel, as shown in Figure 2. The parcel is in equilibrium and on the point of slipping up the plane. The normal reaction of the plane on the parcel is 18 N. The coefficient of friction between the parcel and the plane is μ . Find

(a) the value of P , (4)

(b) the value of μ . (5)

The horizontal force is removed.

(c) Determine whether or not the parcel moves. (5)

6. [In this question the horizontal unit vectors \mathbf{i} and \mathbf{j} are due east and due north respectively.]

A model boat A moves on a lake with constant velocity $(-\mathbf{i} + 6\mathbf{j})$ m s $^{-1}$. At time $t = 0$, A is at the point with position vector $(2\mathbf{i} - 10\mathbf{j})$ m. Find

(a) the speed of A , (2)

(b) the direction in which A is moving, giving your answer as a bearing. (3)

At time $t = 0$, a second boat B is at the point with position vector $(-26\mathbf{i} + 4\mathbf{j})$ m.

Given that the velocity of B is $(3\mathbf{i} + 4\mathbf{j})$ m s $^{-1}$,

(c) show that A and B will collide at a point P and find the position vector of P . (5)

Given instead that B has speed 8 m s $^{-1}$ and moves in the direction of the vector $(3\mathbf{i} + 4\mathbf{j})$,

(d) find the distance of B from P when $t = 7$ s. (6)

7.

Figure 3

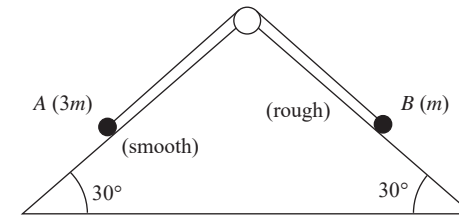

A fixed wedge has two plane faces, each inclined at 30° to the horizontal. Two particles A and B , of mass $3m$ and m respectively, are attached to the ends of a light inextensible string. Each particle moves on one of the plane faces of the wedge. The string passes over a smooth light pulley fixed at the top of the wedge. The face on which A moves is smooth. The face on which B moves is rough. The coefficient of friction between B and this face is μ . Particle A is held at rest with the string taut. The string lies in the same vertical plane as lines of greatest slope on each plane face of the wedge, as shown in Figure 3.

The particles are released from rest and start to move. Particle A moves downwards and particle B moves upwards. The accelerations of A and B each have magnitude $\frac{1}{10}g$.

(a) By considering the motion of A , find, in terms of m and g , the tension in the string. (3)

(b) By considering the motion of B , find the value of μ . (8)

(c) Find the resultant force exerted by the string on the pulley, giving its magnitude and direction. (3)

TOTAL FOR PAPER: 75 MARKS

END

Paper Reference(s)

6677**Edexcel GCE****Mechanics M1****Advanced Subsidiary****Tuesday 6 June 2006 – Afternoon****Time: 1 hour 30 minutes**Materials required for examination
Mathematical Formulae (Lilac or Green)Items included with question papers
Nil

Candidates may use any calculator EXCEPT those with the facility for symbolic algebra, differentiation and/or integration. Thus candidates may NOT use calculators such as the Texas Instruments TI 89, TI 92, Casio CFX 9970G, Hewlett Packard HP 48G.

Instructions to Candidates

In the boxes on the answer book, write the name of the examining body (Edexcel), your centre number, candidate number, the unit title (Mechanics M1), the paper reference (6677), your surname, other name and signature.

Whenever a numerical value of g is required, take $g = 9.8 \text{ m s}^{-2}$.

When a calculator is used, the answer should be given to an appropriate degree of accuracy.

Information for Candidates

A booklet 'Mathematical Formulae and Statistical Tables' is provided.

Full marks may be obtained for answers to ALL questions.

There are 7 questions in this question paper.

The total mark for this paper is 75.

Advice to Candidates

You must ensure that your answers to parts of questions are clearly labelled.

You must show sufficient working to make your methods clear to the Examiner. Answers without working may gain no credit.

N22331A

This publication may only be reproduced in accordance with London Qualifications Limited copyright policy.
©2006 London Qualifications Limited.

1.

Figure 1

Figure 1 shows the speed-time graph of a cyclist moving on a straight road over a 7 s period. The sections of the graph from $t = 0$ to $t = 3$, and from $t = 3$ to $t = 7$, are straight lines. The section from $t = 3$ to $t = 7$ is parallel to the t -axis.

State what can be deduced about the motion of the cyclist from the fact that

- (a) the graph from $t = 0$ to $t = 3$ is a straight line, (1)
- (b) the graph from $t = 3$ to $t = 7$ is parallel to the t -axis. (1)
- (c) Find the distance travelled by the cyclist during this 7 s period. (4)
-

2. Two particles A and B have mass 0.4 kg and 0.3 kg respectively. They are moving in opposite directions on a smooth horizontal table and collide directly. Immediately before the collision, the speed of A is 6 m s^{-1} and the speed of B is 2 m s^{-1} . As a result of the collision, the direction of motion of B is reversed and its speed immediately after the collision is 3 m s^{-1} . Find

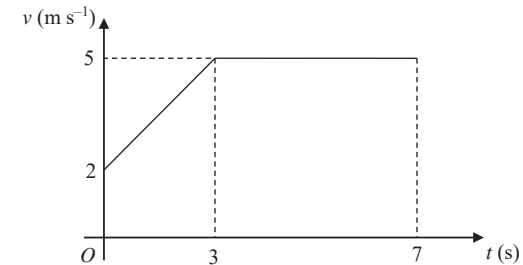
- (a) the speed of A immediately after the collision, stating clearly whether the direction of motion of A is changed by the collision, (4)
- (b) the magnitude of the impulse exerted on B in the collision, stating clearly the units in which your answer is given. (3)
-

N22331A

2

3. A train moves along a straight track with constant acceleration. Three telegraph poles are set at equal intervals beside the track at points A , B and C , where $AB = 50$ m and $BC = 50$ m. The front of the train passes A with speed 22.5 m s⁻¹, and 2 s later it passes B . Find

- (a) the acceleration of the train, (3)
- (b) the speed of the front of the train when it passes C , (3)
- (c) the time that elapses from the instant the front of the train passes B to the instant it passes C . (4)
-

4. **Figure 2**

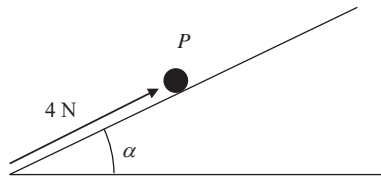

A particle P of mass 0.5 kg is on a rough plane inclined at an angle α to the horizontal, where $\tan \alpha = \frac{3}{4}$. The particle is held at rest on the plane by the action of a force of magnitude 4 N acting up the plane in a direction parallel to a line of greatest slope of the plane, as shown in Figure 2. The particle is on the point of slipping up the plane.

- (a) Find the coefficient of friction between P and the plane. (7)

The force of magnitude 4 N is removed.

- (b) Find the acceleration of P down the plane. (4)
-

- 5.

Figure 3

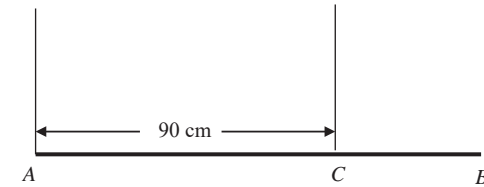

A steel girder AB has weight 210 N. It is held in equilibrium in a horizontal position by two vertical cables. One cable is attached to the end A . The other cable is attached to the point C on the girder, where $AC = 90$ cm, as shown in Figure 3. The girder is modelled as a uniform rod, and the cables as light inextensible strings.

Given that the tension in the cable at C is twice the tension in the cable at A , find

- (a) the tension in the cable at A , (2)

- (b) show that $AB = 120$ cm. (4)

A small load of weight W newtons is attached to the girder at B . The load is modelled as a particle. The girder remains in equilibrium in a horizontal position. The tension in the cable at C is now three times the tension in the cable at A .

- (c) Find the value of W . (7)
-

6. A car is towing a trailer along a straight horizontal road by means of a horizontal tow-rope. The mass of the car is 1400 kg. The mass of the trailer is 700 kg. The car and the trailer are modelled as particles and the tow-rope as a light inextensible string. The resistances to motion of the car and the trailer are assumed to be constant and of magnitude 630 N and 280 N respectively. The driving force on the car, due to its engine, is 2380 N. Find

- (a) the acceleration of the car, (3)

- (b) the tension in the tow-rope. (3)

When the car and trailer are moving at 12 m s⁻¹, the tow-rope breaks. Assuming that the driving force on the car and the resistances to motion are unchanged,

- (c) find the distance moved by the car in the first 4 s after the tow-rope breaks. (6)

- (d) State how you have used the modelling assumption that the tow-rope is inextensible. (1)
-

7. [In this question the unit vectors \mathbf{i} and \mathbf{j} are due east and north respectively]

A ship S is moving with constant velocity $(-2.5\mathbf{i} + 6\mathbf{j}) \text{ km h}^{-1}$. At time 1200, the position vector of S relative to a fixed origin O is $(16\mathbf{i} + 5\mathbf{j}) \text{ km}$. Find

(a) the speed of S , (2)

(b) the bearing on which S is moving. (2)

The ship is heading directly towards a submerged rock R . A radar tracking station calculates that, if S continues on the same course with the same speed, it will hit R at the time 1500.

(c) Find the position vector of R . (2)

The tracking station warns the ship's captain of the situation. The captain maintains S on its course with the same speed until the time is 1400. He then changes course so that S moves due north at a constant speed of 5 km h^{-1} . Assuming that S continues to move with this new constant velocity, find

(d) an expression for the position vector of the ship t hours after 1400, (4)

(e) the time when S will be due east of R , (2)

(f) the distance of S from R at the time 1600. (3)

TOTAL FOR PAPER: 75 MARKS

END

Paper Reference(s)

6677/01

Edexcel GCE

Mechanics M1

Advanced Subsidiary

Friday 12 January 2007 – Morning

Time: 1 hour 30 minutes

Materials required for examination

Mathematical Formulae (Green or Lilac)

Items included with question papers

Nil

Candidates may use any calculator EXCEPT those with the facility for symbolic algebra, differentiation and/or integration. Thus candidates may NOT use calculators such as the Texas Instruments TI 89, TI 92, Casio CFX 9970G, Hewlett Packard HP 48G.

Instructions to Candidates

Write your centre number, candidate number, your surname, initials and signature.

Whenever a numerical value of g is required, take $g = 9.8 \text{ m s}^{-2}$.

When a calculator is used, the answer should be given to an appropriate degree of accuracy.

Information for Candidates

A booklet 'Mathematical Formulae and Statistical Tables' is provided.

Full marks may be obtained for answers to ALL questions.

The marks for individual questions and the parts of questions are shown in round brackets: e.g. (2).

There are 7 questions on this paper. The total mark for this paper is 75.

Advice to Candidates

You must ensure that your answers to parts of questions are clearly labelled.

You must show sufficient working to make your methods clear to the Examiner. Answers without working may gain no credit.

N23560A

This publication may only be reproduced in accordance with Edexcel Limited copyright policy.
©2007 Edexcel Limited.

1.

Figure 1

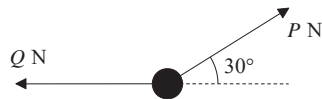

A particle of weight 24 N is held in equilibrium by two light inextensible strings. One string is horizontal. The other string is inclined at an angle of 30° to the horizontal, as shown in Figure 1. The tension in the horizontal string is Q newtons and the tension in the other string is P newtons. Find

- (a) the value of P , (3)
- (b) the value of Q , (3)

2.

Figure 2

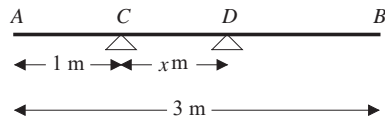

A uniform plank AB has weight 120 N and length 3 m. The plank rests horizontally in equilibrium on two smooth supports C and D , where $AC = 1$ m and $CD = x$ m, as shown in Figure 2. The reaction of the support on the plank at D has magnitude 80 N. Modelling the plank as a rod,

- (a) show that $x = 0.75$. (3)
- A rock is now placed at B and the plank is on the point of tilting about D . Modelling the rock as a particle, find
- (b) the weight of the rock, (4)
- (c) the magnitude of the reaction of the support on the plank at D . (2)
- (d) State how you have used the model of the rock as a particle. (1)

3. A particle P of mass 2 kg is moving under the action of a constant force \mathbf{F} newtons. When $t = 0$, P has velocity $(3\mathbf{i} + 2\mathbf{j})$ m s $^{-1}$ and at time $t = 4$ s, P has velocity $(15\mathbf{i} - 4\mathbf{j})$ m s $^{-1}$. Find

- (a) the acceleration of P in terms of \mathbf{i} and \mathbf{j} , (2)
- (b) the magnitude of \mathbf{F} , (4)
- (c) the velocity of P at time $t = 6$ s. (3)

4. A particle P of mass 0.3 kg is moving with speed u ms $^{-1}$ in a straight line on a smooth horizontal table. The particle P collides directly with a particle Q of mass 0.6 kg, which is at rest on the table. Immediately after the particles collide, P has speed 2 m s $^{-1}$ and Q has speed 5 m s $^{-1}$. The direction of motion of P is reversed by the collision. Find

- (a) the value of u . (4)
- (b) the magnitude of the impulse exerted by P on Q . (2)

Immediately after the collision, a constant force of magnitude R newtons is applied to Q in the direction directly opposite to the direction of motion of Q . As a result Q is brought to rest in 1.5 s.

- (c) Find the value of R . (4)

5. A ball is projected vertically upwards with speed 21 m s $^{-1}$ from a point A , which is 1.5 m above the ground. After projection, the ball moves freely under gravity until it reaches the ground. Modelling the ball as a particle, find

- (a) the greatest height above A reached by the ball, (3)
- (b) the speed of the ball as it reaches the ground, (3)
- (c) the time between the instant when the ball is projected from A and the instant when the ball reaches the ground. (4)

6.

Figure 3

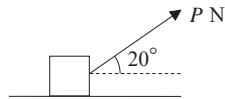

A box of mass 30 kg is being pulled along rough horizontal ground at a constant speed using a rope. The rope makes an angle of 20° with the ground, as shown in Figure 3. The coefficient of friction between the box and the ground is 0.4. The box is modelled as a particle and the rope as a light, inextensible string. The tension in the rope is P newtons.

(a) Find the value of P .

(8)

The tension in the rope is now increased to 150 N.

(b) Find the acceleration of the box.

(6)

7.

Figure 4

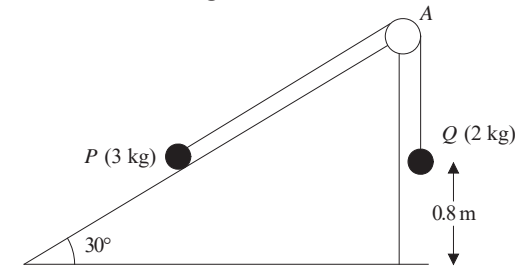

Figure 4 shows two particles P and Q , of mass 3 kg and 2 kg respectively, connected by a light inextensible string. Initially P is held at rest on a smooth fixed plane inclined at 30° to the horizontal. The string passes over a small smooth light pulley A fixed at the top of the plane. The part of the string from P to A is parallel to a line of greatest slope of the plane. The particle Q hangs freely below A . The system is released from rest with the string taut.

(a) Write down an equation of motion for P and an equation of motion for Q .

(4)

(b) Hence show that the acceleration of Q is 0.98 m s^{-2} .

(2)

(c) Find the tension in the string.

(2)

(d) State where in your calculations you have used the information that the string is inextensible.

(1)

On release, Q is at a height of 0.8 m above the ground. When Q reaches the ground, it is brought to rest immediately by the impact with the ground and does not rebound. The initial distance of P from A is such that in the subsequent motion P does not reach A . Find

(e) the speed of Q as it reaches the ground,

(2)

(f) the time between the instant when Q reaches the ground and then instant when the string becomes taut again.

(5)

TOTAL FOR PAPER: 75 MARKS

END

Paper Reference(s)

6677**Edexcel GCE****Mechanics M1****Advanced/Advanced Subsidiary****Thursday 7 June 2007 – Morning****Time: 1 hour 30 minutes****Materials required for examination**

Mathematical Formulae (Green)

Items included with question papers

Nil

Candidates may use any calculator allowed by the regulations of the Joint Council for Qualifications. Calculators must not have the facility for symbolic algebra manipulation, differentiation and integration, or have retrievable mathematical formulas stored in them.

Instructions to Candidates

In the boxes on the answer book, write the name of the examining body (Edexcel), your centre number, candidate number, the unit title (Mechanics M1), the paper reference (6677), your surname, other name and signature.

Whenever a numerical value of g is required, take $g = 9.8 \text{ m s}^{-2}$.

When a calculator is used, the answer should be given to an appropriate degree of accuracy.

Information for Candidates

A booklet 'Mathematical Formulae and Statistical Tables' is provided.

Full marks may be obtained for answers to ALL questions.

There are 7 questions in this question paper.

The total mark for this paper is 75.

Advice to Candidates

You must ensure that your answers to parts of questions are clearly labelled.

You must show sufficient working to make your methods clear to the Examiner. Answers without working may gain no credit.

N26114A

This publication may only be reproduced in accordance with Edexcel Limited copyright policy.
©2007 Edexcel Limited.

1.

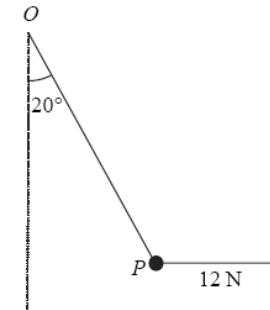
Figure 1

A particle P is attached to one end of a light inextensible string. The other end of the string is attached to a fixed point O . A horizontal force of magnitude 12 N is applied to P . The particle P is in equilibrium with the string taut and OP making an angle of 20° with the downward vertical, as shown in Figure 1.

Find

- (a) the tension in the string, (3)
- (b) the weight of P . (4)

2. Two particles A and B , of mass 0.3 kg and m kg respectively, are moving in opposite directions along the same straight horizontal line so that the particles collide directly. Immediately before the collision, the speeds of A and B are 8 m s^{-1} and 4 m s^{-1} respectively. In the collision the direction of motion of each particle is reversed and, immediately after the collision, the speed of each particle is 2 m s^{-1} .

Find

- (a) the magnitude of the impulse exerted by B on A in the collision, (3)
- (b) the value of m . (4)

N26114A

2

3.

Figure 3

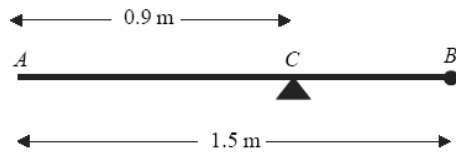

A uniform rod AB has length 1.5 m and mass 8 kg. A particle of mass m kg is attached to the rod at B . The rod is supported at the point C , where $AC = 0.9$ m, and the system is in equilibrium with AB horizontal, as shown in Figure 2.

- (a) Show that $m = 2$. (4)

A particle of mass 5 kg is now attached to the rod at A and the support is moved from C to a point D of the rod. The system, including both particles, is again in equilibrium with AB horizontal.

- (b) Find the distance AD . (5)
-

4. A car is moving along a straight horizontal road. At time $t = 0$, the car passes a point A with speed 25 m s^{-1} . The car moves with constant speed 25 m s^{-1} until $t = 10$ s. The car then decelerates uniformly for 8 s. At time $t = 18$ s, the speed of the car is $V \text{ m s}^{-1}$ and this speed is maintained until the car reaches the point B at time $t = 30$ s.

- (a) Sketch a speed–time graph to show the motion of the car from A to B . (3)

Given that $AB = 526$ m, find

- (b) the value of V , (5)
- (c) the deceleration of the car between $t = 10$ s and $t = 18$ s. (3)
-

5.

Figure 3

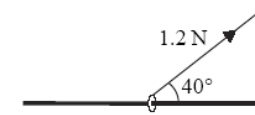

A small ring of mass 0.25 kg is threaded on a fixed rough horizontal rod. The ring is pulled upwards by a light string which makes an angle 40° with the horizontal, as shown in Figure 3. The string and the rod are in the same vertical plane. The tension in the string is 1.2 N and the coefficient of friction between the ring and the rod is μ . Given that the ring is in limiting equilibrium, find

- (a) the normal reaction between the ring and the rod, (4)
- (b) the value of μ . (6)
-

6.

Figure 4

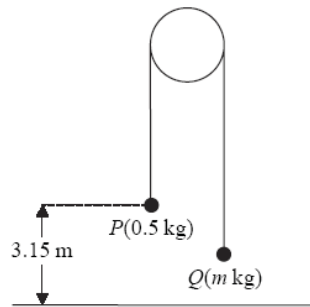

Two particles P and Q have mass 0.5 kg and m kg respectively, where $m < 0.5$. The particles are connected by a light inextensible string which passes over a smooth, fixed pulley. Initially P is 3.15 m above horizontal ground. The particles are released from rest with the string taut and the hanging parts of the string vertical, as shown in Figure 4. After P has been descending for 1.5 s, it strikes the ground. Particle P reaches the ground before Q has reached the pulley.

- (a) Show that the acceleration of P as it descends is 2.8 m s^{-2} . (3)
- (b) Find the tension in the string as P descends. (3)
- (c) Show that $m = \frac{5}{18}$. (4)
- (d) State how you have used the information that the string is inextensible. (1)

When P strikes the ground, P does not rebound and the string becomes slack. Particle Q then moves freely under gravity, without reaching the pulley, until the string becomes taut again.

- (e) Find the time between the instant when P strikes the ground and the instant when the string becomes taut again. (6)

7. A boat B is moving with constant velocity. At noon, B is at the point with position vector $(3\mathbf{i} - 4\mathbf{j})$ km with respect to a fixed origin O . At 1430 on the same day, B is at the point with position vector $(8\mathbf{i} + 11\mathbf{j})$ km.

- (a) Find the velocity of B , giving your answer in the form $p\mathbf{i} + q\mathbf{j}$. (3)

At time t hours after noon, the position vector of B is \mathbf{b} km.

- (b) Find, in terms of t , an expression for \mathbf{b} . (3)

Another boat C is also moving with constant velocity. The position vector of C , \mathbf{c} km, at time t hours after noon, is given by

$$\mathbf{c} = (-9\mathbf{i} + 20\mathbf{j}) + t(6\mathbf{i} + \lambda\mathbf{j}),$$

where λ is a constant.

Given that C intercepts B ,

- (c) find the value of λ , (5)
- (d) show that, before C intercepts B , the boats are moving with the same speed. (3)

TOTAL FOR PAPER: 75 MARKS

END

Paper Reference(s)

6677/01**Edexcel GCE****Mechanics M1****Advanced Subsidiary****Friday 11 January 2008 – Morning****Time: 1 hour 30 minutes****Materials required for examination**

Mathematical Formulae (Green)

Items included with question papers

Nil

Candidates may use any calculator allowed by the regulations of the Joint Council for Qualifications. Calculators must not have the facility for symbolic algebra manipulation, differentiation and integration, or have retrievable mathematical formulae stored in them.

Instructions to Candidates

Write your centre number, candidate number, your surname, initials and signature.

Whenever a numerical value of g is required, take $g = 9.8 \text{ m s}^{-2}$.

When a calculator is used, the answer should be given to an appropriate degree of accuracy.

Information for Candidates

A booklet 'Mathematical Formulae and Statistical Tables' is provided.

Full marks may be obtained for answers to ALL questions.

The marks for individual questions and the parts of questions are shown in round brackets: e.g. (2).

There are 7 questions on this paper. The total mark for this paper is 75.

Advice to Candidates

You must ensure that your answers to parts of questions are clearly labelled.

You must show sufficient working to make your methods clear to the Examiner. Answers without working may gain no credit.

1. Two particles A and B have masses 4 kg and $m \text{ kg}$ respectively. They are moving towards each other in opposite directions on a smooth horizontal table when they collide directly. Immediately before the collision, the speed of A is 5 m s^{-1} and the speed of B is 3 m s^{-1} . Immediately after the collision, the direction of motion of A is unchanged and the speed of A is 1 m s^{-1} .

(a) Find the magnitude of the impulse exerted on A in the collision.

(2)

Immediately after the collision, the speed of B is 2 m s^{-1} .

(b) Find the value of m .

(4)

2. A firework rocket starts from rest at ground level and moves vertically. In the first 3 s of its motion, the rocket rises 27 m . The rocket is modelled as a particle moving with constant acceleration $a \text{ m s}^{-2}$. Find

(a) the value of a ,

(2)

(b) the speed of the rocket 3 s after it has left the ground.

(2)

After 3 s , the rocket burns out. The motion of the rocket is now modelled as that of a particle moving freely under gravity.

(c) Find the height of the rocket above the ground 5 s after it has left the ground.

(4)

3. A car moves along a horizontal straight road, passing two points A and B . At A the speed of the car is 15 m s^{-1} . When the driver passes A , he sees a warning sign W ahead of him, 120 m away. He immediately applies the brakes and the car decelerates with uniform deceleration, reaching W with speed 5 m s^{-1} . At W , the driver sees that the road is clear. He then immediately accelerates the car with uniform acceleration for 16 s to reach a speed of $V \text{ m s}^{-1}$ ($V > 15$). He then maintains the car at a constant speed of $V \text{ m s}^{-1}$. Moving at this constant speed, the car passes B after a further 22 s .

(a) Sketch, in the space below, a speed-time graph to illustrate the motion of the car as it moves from A to B .

(3)

(b) Find the time taken for the car to move from A to B .

(3)

The distance from A to B is 1 km .

(c) Find the value of V .

(5)

N26331A

This publication may only be reproduced in accordance with Edexcel Limited copyright policy.
©2008 Edexcel Limited.

N26331A

2

4.

Figure 1

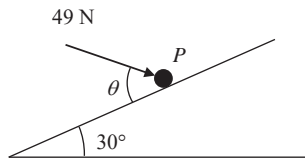

A particle P of mass 6 kg lies on the surface of a smooth plane. The plane is inclined at an angle of 30° to the horizontal. The particle is held in equilibrium by a force of magnitude 49 N , acting at an angle θ to the plane, as shown in Figure 1. The force acts in a vertical plane through a line of greatest slope of the plane.

- (a) Show that $\cos \theta = \frac{3}{5}$. (3)
- (b) Find the normal reaction between P and the plane. (4)

The direction of the force of magnitude 49 N is now changed. It is now applied horizontally to P so that P moves up the plane. The force again acts in a vertical plane through a line of greatest slope of the plane.

- (c) Find the initial acceleration of P . (4)
-

5.

Figure 2

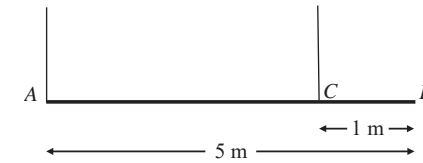

A beam AB has mass 12 kg and length 5 m . It is held in equilibrium in a horizontal position by two vertical ropes attached to the beam. One rope is attached to A , the other to the point C on the beam, where $BC = 1 \text{ m}$, as shown in Figure 2. The beam is modelled as a uniform rod, and the ropes as light strings.

- (a) Find
- (i) the tension in the rope at C ,
 - (ii) the tension in the rope at A . (5)

A small load of mass 16 kg is attached to the beam at a point which is y metres from A . The load is modelled as a particle. Given that the beam remains in equilibrium in a horizontal position,

- (b) find, in terms of y , an expression for the tension in the rope at C . (3)

The rope at C will break if its tension exceeds 98 N . The rope at A cannot break.

- (c) Find the range of possible positions on the beam where the load can be attached without the rope at C breaking. (3)
-

6. [In this question, the unit vectors \mathbf{i} and \mathbf{j} are due east and due north respectively.]

A particle P is moving with constant velocity $(-5\mathbf{i} + 8\mathbf{j}) \text{ m s}^{-1}$. Find

- (a) the speed of P , (2)
- (b) the direction of motion of P , giving your answer as a bearing. (3)

At time $t = 0$, P is at the point A with position vector $(7\mathbf{i} - 10\mathbf{j}) \text{ m}$ relative to a fixed origin O . When $t = 3 \text{ s}$, the velocity of P changes and it moves with velocity $(u\mathbf{i} + v\mathbf{j}) \text{ m s}^{-1}$, where u and v are constants. After a further 4 s , it passes through O and continues to move with velocity $(u\mathbf{i} + v\mathbf{j}) \text{ m s}^{-1}$.

- (c) Find the values of u and v . (5)
- (d) Find the total time taken for P to move from A to a position which is due south of A . (3)
-

7.

Figure 3



Two particles A and B , of mass m and $2m$ respectively, are attached to the ends of a light inextensible string. The particle A lies on a rough horizontal table. The string passes over a small smooth pulley P fixed on the edge of the table. The particle B hangs freely below the pulley, as shown in Figure 3. The coefficient of friction between A and the table is μ . The particles are released from rest with the string taut. Immediately after release, the magnitude of the acceleration of A and B is $\frac{4}{9}g$. By writing down separate equations of motion for A and B ,

- (a) find the tension in the string immediately after the particles begin to move, (3)
- (b) show that $\mu = \frac{2}{3}$. (5)

When B has fallen a distance h , it hits the ground and does not rebound. Particle A is then a distance $\frac{1}{3}h$ from P .

- (c) Find the speed of A as it reaches P . (6)
- (d) State how you have used the information that the string is light. (1)

TOTAL FOR PAPER: 75 MARKS

END

Paper Reference(s)

6677**Edexcel GCE****Mechanics M1****Advanced/Advanced Subsidiary****Wednesday 21 May 2008 – Afternoon****Time: 1 hour 30 minutes****Materials required for examination**

Mathematical Formulae (Green)

Items included with question papers

Nil

Candidates may use any calculator allowed by the regulations of the Joint Council for Qualifications. Calculators must not have the facility for symbolic algebra manipulation, differentiation and integration, or have retrievable mathematical formulas stored in them.

Instructions to Candidates

In the boxes on the answer book, write the name of the examining body (Edexcel), your centre number, candidate number, the unit title (Mechanics M1), the paper reference (6677), your surname, other name and signature.

Whenever a numerical value of g is required, take $g = 9.8 \text{ m s}^{-2}$.

When a calculator is used, the answer should be given to an appropriate degree of accuracy.

Information for Candidates

A booklet 'Mathematical Formulae and Statistical Tables' is provided.

Full marks may be obtained for answers to ALL questions.

There are 8 questions in this question paper.

The total mark for this paper is 75.

Advice to Candidates

You must ensure that your answers to parts of questions are clearly labelled.

You must show sufficient working to make your methods clear to the Examiner.

Answers without working may gain no credit.

1. Two particles P and Q have mass 0.4 kg and 0.6 kg respectively. The particles are initially at rest on a smooth horizontal table. Particle P is given an impulse of magnitude 3 N s in the direction PQ .

(a) Find the speed of P immediately before it collides with Q . (3)

Immediately after the collision between P and Q , the speed of Q is 5 m s^{-1} .

(b) Show that immediately after the collision P is at rest. (3)

2. At time $t = 0$, a particle is projected vertically upwards with speed $u \text{ m s}^{-1}$ from a point 10 m above the ground. At time T seconds, the particle hits the ground with speed 17.5 m s^{-1} . Find

(a) the value of u , (3)

(b) the value of T . (4)

3. A particle P of mass 0.4 kg moves under the action of a single constant force \mathbf{F} newtons. The acceleration of P is $(6\mathbf{i} + 8\mathbf{j}) \text{ m s}^{-2}$. Find

(a) the angle between the acceleration and \mathbf{i} , (2)

(b) the magnitude of \mathbf{F} . (3)

At time t seconds the velocity of P is $\mathbf{v} \text{ m s}^{-1}$. Given that when $t = 0$, $\mathbf{v} = 9\mathbf{i} - 10\mathbf{j}$,

(c) find the velocity of P when $t = 5$. (3)

4. A car is moving along a straight horizontal road. The speed of the car as it passes the point A is 25 m s^{-1} and the car maintains this speed for 30 s. The car then decelerates uniformly to a speed of 10 m s^{-1} . The speed of 10 m s^{-1} is then maintained until the car passes the point B . The time taken to travel from A to B is 90 s and $AB = 1410 \text{ m}$.

- (a) Sketch a speed-time graph to show the motion of the car from A to B . (2)
- (b) Calculate the deceleration of the car as it decelerates from 25 m s^{-1} to 10 m s^{-1} . (7)
-

5.

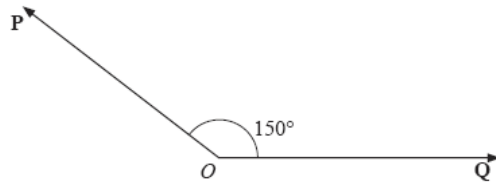

Figure 1

Two forces \mathbf{P} and \mathbf{Q} act on a particle at a point O . The force \mathbf{P} has magnitude 15 N and the force \mathbf{Q} has magnitude X newtons. The angle between \mathbf{P} and \mathbf{Q} is 150° , as shown in Figure 1. The resultant of \mathbf{P} and \mathbf{Q} is \mathbf{R} .

Given that the angle between \mathbf{R} and \mathbf{Q} is 50° , find

- (a) the magnitude of \mathbf{R} , (4)
- (b) the value of X . (5)
-

6.

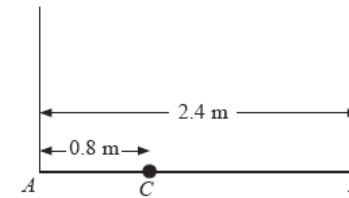

Figure 2

A plank AB has mass 12 kg and length 2.4 m. A load of mass 8 kg is attached to the plank at the point C , where $AC = 0.8 \text{ m}$. The loaded plank is held in equilibrium, with AB horizontal, by two vertical ropes, one attached at A and the other attached at B , as shown in Figure 2. The plank is modelled as a uniform rod, the load as a particle and the ropes as light inextensible strings.

- (a) Find the tension in the rope attached at B . (4)

The plank is now modelled as a non-uniform rod. With the new model, the tension in the rope attached at A is 10 N greater than the tension in the rope attached at B .

- (b) Find the distance of the centre of mass of the plank from A . (6)
-

7.

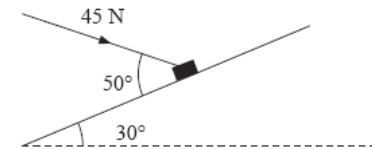

Figure 3

A package of mass 4 kg lies on a rough plane inclined at 30° to the horizontal. The package is held in equilibrium by a force of magnitude 45 N acting at an angle of 50° to the plane, as shown in Figure 3. The force is acting in a vertical plane through a line of greatest slope of the plane. The package is in equilibrium on the point of moving up the plane. The package is modelled as a particle. Find

- (a) the magnitude of the normal reaction of the plane on the package, (5)

- (b) the coefficient of friction between the plane and the package. (6)
-

8.



Figure 4

Two particles P and Q , of mass 2 kg and 3 kg respectively, are joined by a light inextensible string. Initially the particles are at rest on a rough horizontal plane with the string taut. A constant force F of magnitude 30 N is applied to Q in the direction PQ , as shown in Figure 4. The force is applied for 3 s and during this time Q travels a distance of 6 m. The coefficient of friction between each particle and the plane is μ . Find

- (a) the acceleration of Q , (2)
- (b) the value of μ , (4)
- (c) the tension in the string. (4)
- (d) State how in your calculation you have used the information that the string is inextensible. (1)
- When the particles have moved for 3 s, the force F is removed.
- (e) Find the time between the instant that the force is removed and the instant that Q comes to rest. (4)

TOTAL FOR PAPER: 75 MARKS

END

Paper Reference(s)

6677**Edexcel GCE****Mechanics M1****Advanced Subsidiary****Tuesday 13 January 2009 – Morning****Time: 1 hour 30 minutes**Materials required for examination

Mathematical Formulae (Green)

Items included with question papers

Nil

Candidates may use any calculator allowed by the regulations of the Joint Council for Qualifications. Calculators must not have the facility for symbolic algebra manipulation, differentiation and integration, or have retrievable mathematical formulas stored in them.

Instructions to Candidates

In the boxes on the answer book, write the name of the examining body (Edexcel), your centre number, candidate number, the unit title (Mechanics M1), the paper reference (6677), your surname, other name and signature.

Whenever a numerical value of g is required, take $g = 9.8 \text{ m s}^{-2}$.

When a calculator is used, the answer should be given to an appropriate degree of accuracy.

Information for Candidates

A booklet 'Mathematical Formulae and Statistical Tables' is provided.

Full marks may be obtained for answers to ALL questions.

There are 7 questions in this question paper.

The total mark for this paper is 75.

Advice to Candidates

You must ensure that your answers to parts of questions are clearly labelled.

You must show sufficient working to make your methods clear to the Examiner.

Answers without working may not gain full credit.

N29411A

This publication may only be reproduced in accordance with Edexcel Limited copyright policy.
©2009 Edexcel Limited.

1. A particle P moves with constant acceleration $(2\mathbf{i} - 5\mathbf{j}) \text{ m s}^{-2}$. At time $t = 0$, P has speed $u \text{ m s}^{-1}$. At time $t = 3 \text{ s}$, P has velocity $(-6\mathbf{i} + \mathbf{j}) \text{ m s}^{-1}$.

Find the value of u .

(5)

2. A small ball is projected vertically upwards from ground level with speed $u \text{ m s}^{-1}$. The ball takes 4 s to return to ground level.

(a) Draw, in the space below, a velocity-time graph to represent the motion of the ball during the first 4 s .

(2)

(b) The maximum height of the ball above the ground during the first 4 s is 19.6 m . Find the value of u .

(3)

3. Two particles A and B are moving on a smooth horizontal plane. The mass of A is km , where $2 < k < 3$, and the mass of B is m . The particles are moving along the same straight line, but in opposite directions, and they collide directly. Immediately before they collide the speed of A is $2u$ and the speed of B is $4u$. As a result of the collision the speed of A is halved and its direction of motion is reversed.

(a) Find, in terms of k and u , the speed of B immediately after the collision.

(3)

(b) State whether the direction of motion of B changes as a result of the collision, explaining your answer.

(3)

Given that $k = \frac{7}{3}$,

(c) find, in terms of m and u , the magnitude of the impulse that A exerts on B in the collision.

(3)

4.

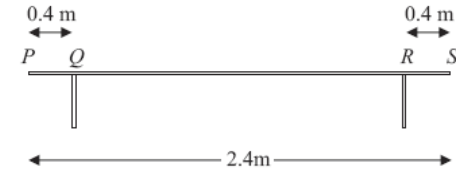

Figure 1

A bench consists of a plank which is resting in a horizontal position on two thin vertical legs. The plank is modelled as a uniform rod PS of length 2.4 m and mass 20 kg . The legs at Q and R are 0.4 m from each end of the plank, as shown in Figure 1.

Two pupils, Arthur and Beatrice, sit on the plank. Arthur has mass 60 kg and sits at the middle of the plank and Beatrice has mass 40 kg and sits at the end P . The plank remains horizontal and in equilibrium. By modelling the pupils as particles, find

(a) the magnitude of the normal reaction between the plank and the leg at Q and the magnitude of the normal reaction between the plank and the leg at R .

(7)

Beatrice stays sitting at P but Arthur now moves and sits on the plank at the point X . Given that the plank remains horizontal and in equilibrium, and that the magnitude of the normal reaction between the plank and the leg at Q is now twice the magnitude of the normal reaction between the plank and the leg at R ,

(b) find the distance QX .

(6)

5.

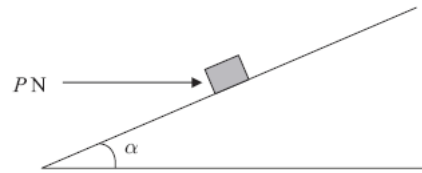

Figure 2

A small package of mass 1.1 kg is held in equilibrium on a rough plane by a horizontal force. The plane is inclined at an angle α to the horizontal, where $\tan \alpha = \frac{3}{4}$. The force acts in a vertical plane containing a line of greatest slope of the plane and has magnitude P newtons, as shown in Figure 2.

The coefficient of friction between the package and the plane is 0.5 and the package is modelled as a particle. The package is in equilibrium and on the point of slipping down the plane.

- (a) Draw, on Figure 2, all the forces acting on the package, showing their directions clearly. (2)
- (b) (i) Find the magnitude of the normal reaction between the package and the plane.
(ii) Find the value of P . (11)

6. Two forces, $(4\mathbf{i} - 5\mathbf{j})$ N and $(p\mathbf{i} + q\mathbf{j})$ N, act on a particle P of mass m kg. The resultant of the two forces is \mathbf{R} . Given that \mathbf{R} acts in a direction which is parallel to the vector $(\mathbf{i} - 2\mathbf{j})$,

- (a) find the angle between \mathbf{R} and the vector \mathbf{j} , (3)
- (b) show that $2p + q + 3 = 0$. (4)

Given also that $q = 1$ and that P moves with an acceleration of magnitude $8\sqrt{5} \text{ m s}^{-2}$,

- (c) find the value of m . (7)

7.

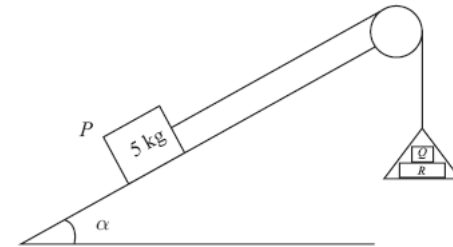

Figure 3

One end of a light inextensible string is attached to a block P of mass 5 kg. The block P is held at rest on a smooth fixed plane which is inclined to the horizontal at an angle α , where $\sin \alpha = \frac{3}{5}$. The string lies along a line of greatest slope of the plane and passes over a smooth light pulley which is fixed at the top of the plane. The other end of the string is attached to a light scale pan which carries two blocks Q and R , with block Q on top of block R , as shown in Figure 3. The mass of block Q is 5 kg and the mass of block R is 10 kg. The scale pan hangs at rest and the system is released from rest. By modelling the blocks as particles, ignoring air resistance and assuming the motion is uninterrupted, find

- (a) (i) the acceleration of the scale pan,
(ii) the tension in the string, (8)
- (b) the magnitude of the force exerted on block Q by block R , (3)
- (c) the magnitude of the force exerted on the pulley by the string. (5)

TOTAL FOR PAPER: 75 MARKS

END

Paper Reference(s)

6677**Edexcel GCE****Mechanics M1****Advanced/Advanced Subsidiary****Friday 22 May 2009 – Morning****Time: 1 hour 30 minutes****Materials required for examination**
Mathematical Formulae (Orange or Green)**Items included with question papers**
Nil

Candidates may use any calculator allowed by the regulations of the Joint Council for Qualifications. Calculators must not have the facility for symbolic algebra manipulation, differentiation and integration, or have retrievable mathematical formulae stored in them.

Instructions to Candidates

In the boxes on the answer book, write the name of the examining body (Edexcel), your centre number, candidate number, the unit title (Mechanics M1), the paper reference (6677), your surname, other name and signature.

Whenever a numerical value of g is required, take $g = 9.8 \text{ m s}^{-2}$.

When a calculator is used, the answer should be given to an appropriate degree of accuracy.

Information for Candidates

A booklet 'Mathematical Formulae and Statistical Tables' is provided.

Full marks may be obtained for answers to ALL questions.

There are 8 questions in this question paper.

The total mark for this paper is 75.

Advice to Candidates

You must ensure that your answers to parts of questions are clearly labelled.

You must show sufficient working to make your methods clear to the Examiner.

Answers without working may not gain full credit.

1. Three posts P , Q and R , are fixed in that order at the side of a straight horizontal road. The distance from P to Q is 45 m and the distance from Q to R is 120 m. A car is moving along the road with constant acceleration $a \text{ m s}^{-2}$. The speed of the car, as it passes P , is $u \text{ m s}^{-1}$. The car passes Q two seconds after passing P , and the car passes R four seconds after passing Q .

Find

(i) the value of u ,(ii) the value of a .

(7)

2. A particle is acted upon by two forces \mathbf{F}_1 and \mathbf{F}_2 , given by

$$\mathbf{F}_1 = (\mathbf{i} - 3\mathbf{j}) \text{ N},$$

$$\mathbf{F}_2 = (p\mathbf{i} + 2p\mathbf{j}) \text{ N}, \text{ where } p \text{ is a positive constant.}$$

(a) Find the angle between \mathbf{F}_2 and \mathbf{j} .

(2)

The resultant of \mathbf{F}_1 and \mathbf{F}_2 is \mathbf{R} . Given that \mathbf{R} is parallel to \mathbf{i} ,(b) find the value of p .

(4)

3. Two particles A and B are moving on a smooth horizontal plane. The mass of A is $2m$ and the mass of B is m . The particles are moving along the same straight line but in opposite directions and they collide directly. Immediately before they collide the speed of A is $2u$ and the speed of B is $3u$. The magnitude of the impulse received by each particle in the collision is $\frac{7mu}{2}$.

Find

(a) the speed of A immediately after the collision,

(3)

(b) the speed of B immediately after the collision.

(3)

4. A small brick of mass 0.5 kg is placed on a rough plane which is inclined to the horizontal at an angle θ , where $\tan \theta = \frac{4}{3}$, and released from rest. The coefficient of friction between the brick and the plane is $\frac{1}{3}$.

Find the acceleration of the brick.

(9)

- 5.

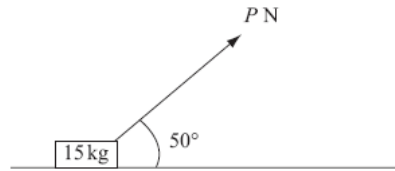

Figure 1

A small box of mass 15 kg rests on a rough horizontal plane. The coefficient of friction between the box and the plane is 0.2. A force of magnitude P newtons is applied to the box at 50° to the horizontal, as shown in Figure 1. The box is on the point of sliding along the plane.

Find the value of P , giving your answer to 2 significant figures.

(9)

6. A car of mass 800 kg pulls a trailer of mass 200 kg along a straight horizontal road using a light towbar which is parallel to the road. The horizontal resistances to motion of the car and the trailer have magnitudes 400 N and 200 N respectively. The engine of the car produces a constant horizontal driving force on the car of magnitude 1200 N. Find

(a) the acceleration of the car and trailer,

(3)

(b) the magnitude of the tension in the towbar.

(3)

The car is moving along the road when the driver sees a hazard ahead. He reduces the force produced by the engine to zero and applies the brakes. The brakes produce a force on the car of magnitude F newtons and the car and trailer decelerate. Given that the resistances to motion are unchanged and the magnitude of the thrust in the towbar is 100 N,

(c) find the value of F .

(7)

- 7.

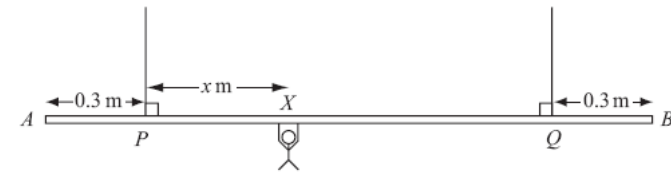

Figure 2

A beam AB is supported by two vertical ropes, which are attached to the beam at points P and Q , where $AP = 0.3$ m and $BQ = 0.3$ m. The beam is modelled as a uniform rod, of length 2 m and mass 20 kg. The ropes are modelled as light inextensible strings. A gymnast of mass 50 kg hangs on the beam between P and Q . The gymnast is modelled as a particle attached to the beam at the point X , where $PX = x$ m, $0 < x < 1.4$ as shown in Figure 2. The beam rests in equilibrium in a horizontal position.

(a) Show that the tension in the rope attached to the beam at P is $(588 - 350x)$ N.

(3)

(b) Find, in terms of x , the tension in the rope attached to the beam at Q .

(3)

(c) Hence find, justifying your answer carefully, the range of values of the tension which could occur in each rope.

(3)

Given that the tension in the rope attached at Q is three times the tension in the rope attached at P ,

(d) find the value of x .

(3)

8. [In this question \mathbf{i} and \mathbf{j} are horizontal unit vectors due east and due north respectively.]

A hiker H is walking with constant velocity $(1.2\mathbf{i} - 0.9\mathbf{j}) \text{ m s}^{-1}$.

- (a) Find the speed of H .

(2)

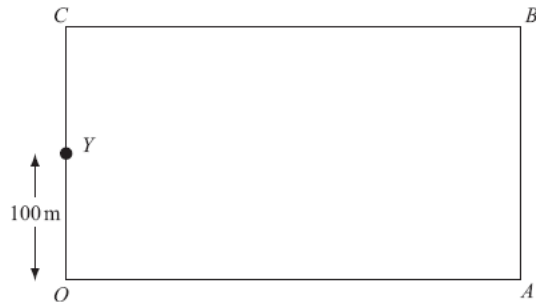

Figure 3

A horizontal field $OABC$ is rectangular with OA due east and OC due north, as shown in Figure 3. At twelve noon hiker H is at the point Y with position vector $100\mathbf{j}$ m, relative to the fixed origin O .

- (b) Write down the position vector of H at time t seconds after noon.

(2)

At noon, another hiker K is at the point with position vector $(9\mathbf{i} + 46\mathbf{j})$ m. Hiker K is moving with constant velocity $(0.75\mathbf{i} + 1.8\mathbf{j}) \text{ m s}^{-1}$.

- (c) Show that, at time t seconds after noon,

$$\overrightarrow{HK} = [(9 - 0.45t)\mathbf{i} + (2.7t - 54)\mathbf{j}] \text{ metres.}$$

(4)

Hence,

- (d) show that the two hikers meet and find the position vector of the point where they meet.

(5)

TOTAL FOR PAPER: 75 MARKS

END

Paper Reference(s)

6677

Edexcel GCE

Mechanics M1

Advanced Subsidiary

Friday 15 January 2010 – Afternoon

Time: 1 hour 30 minutes

Materials required for examination
Mathematical Formulae (Pink or Green)

Items included with question papers
Nil

Candidates may use any calculator allowed by the regulations of the Joint Council for Qualifications. Calculators must not have the facility for symbolic algebra manipulation, differentiation and integration, or have retrievable mathematical formulas stored in them.

Instructions to Candidates

In the boxes on the answer book, write the name of the examining body (Edexcel), your centre number, candidate number, the unit title (Mechanics M1), the paper reference (6677), your surname, other name and signature.

Whenever a numerical value of g is required, take $g = 9.8 \text{ m s}^{-2}$.

When a calculator is used, the answer should be given to an appropriate degree of accuracy.

Information for Candidates

A booklet 'Mathematical Formulae and Statistical Tables' is provided.

Full marks may be obtained for answers to ALL questions.

There are 7 questions in this question paper.

The total mark for this paper is 75.

Advice to Candidates

You must ensure that your answers to parts of questions are clearly labelled.

You must show sufficient working to make your methods clear to the Examiner.

Answers without working may not gain full credit.

N35104A

This publication may only be reproduced in accordance with Edexcel Limited copyright policy.
©2010 Edexcel Limited.

1. A particle A of mass 2 kg is moving along a straight horizontal line with speed 12 m s^{-1} . Another particle B of mass $m\text{ kg}$ is moving along the same straight line, in the opposite direction to A , with speed 8 m s^{-1} . The particles collide. The direction of motion of A is unchanged by the collision. Immediately after the collision, A is moving with speed 3 m s^{-1} and B is moving with speed 4 m s^{-1} . Find

(a) the magnitude of the impulse exerted by B on A in the collision, (2)

(b) the value of m . (4)

2. An athlete runs along a straight road. She starts from rest and moves with constant acceleration for 5 seconds, reaching a speed of 8 m s^{-1} . This speed is then maintained for T seconds. She then decelerates at a constant rate until she stops. She has run a total of 500 m in 75 s .

(a) Sketch a speed-time graph to illustrate the motion of the athlete. (3)

(b) Calculate the value of T . (5)

3.

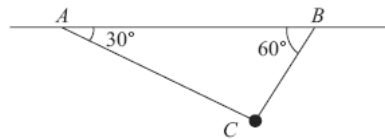

Figure 1

A particle of mass $m\text{ kg}$ is attached at C to two light inextensible strings AC and BC . The other ends of the strings are attached to fixed points A and B on a horizontal ceiling. The particle hangs in equilibrium with AC and BC inclined to the horizontal at 30° and 60° respectively, as shown in Figure 1.

Given that the tension in AC is 20 N , find

(a) the tension in BC , (4)

(b) the value of m . (4)

4.

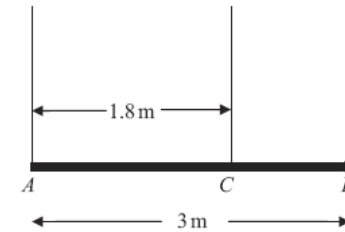

Figure 2

A pole AB has length 3 m and weight W newtons. The pole is held in a horizontal position in equilibrium by two vertical ropes attached to the pole at the points A and C where $AC = 1.8\text{ m}$, as shown in Figure 2. A load of weight 20 N is attached to the rod at B . The pole is modelled as a uniform rod, the ropes as light inextensible strings and the load as a particle.

(a) Show that the tension in the rope attached to the pole at C is $\left(\frac{5}{6}W + \frac{100}{3}\right)\text{ N}$. (4)

(b) Find, in terms of W , the tension in the rope attached to the pole at A . (3)

Given that the tension in the rope attached to the pole at C is eight times the tension in the rope attached to the pole at A ,

(c) find the value of W . (3)

5. A particle of mass 0.8 kg is held at rest on a rough plane. The plane is inclined at 30° to the horizontal. The particle is released from rest and slides down a line of greatest slope of the plane. The particle moves 2.7 m during the first 3 seconds of its motion. Find

- (a) the acceleration of the particle, (3)
 (b) the coefficient of friction between the particle and the plane. (5)

The particle is now held on the same rough plane by a horizontal force of magnitude X newtons, acting in a plane containing a line of greatest slope of the plane, as shown in Figure 3. The particle is in equilibrium and on the point of moving up the plane.

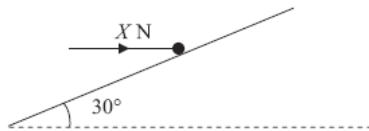

Figure 3

- (c) Find the value of X . (7)
-

- 6.

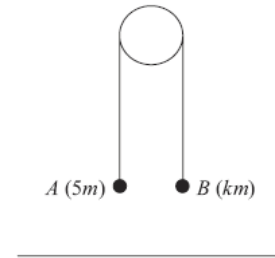

Figure 4

Two particles A and B have masses $5m$ and km respectively, where $k < 5$. The particles are connected by a light inextensible string which passes over a smooth light fixed pulley. The system is held at rest with the string taut, the hanging parts of the string vertical and with A and B at the same height above a horizontal plane, as shown in Figure 4. The system is released from rest. After release, A descends with acceleration $\frac{1}{4}g$.

- (a) Show that the tension in the string as A descends is $\frac{15}{4}mg$. (3)
 (b) Find the value of k . (3)
 (c) State how you have used the information that the pulley is smooth. (1)

After descending for 1.2 s , the particle A reaches the plane. It is immediately brought to rest by the impact with the plane. The initial distance between B and the pulley is such that, in the subsequent motion, B does not reach the pulley.

- (d) Find the greatest height reached by B above the plane. (7)
-

7. [In this question, \mathbf{i} and \mathbf{j} are horizontal unit vectors due east and due north respectively and position vectors are given with respect to a fixed origin.]

A ship S is moving along a straight line with constant velocity. At time t hours the position vector of S is \mathbf{s} km. When $t = 0$, $\mathbf{s} = 9\mathbf{i} - 6\mathbf{j}$. When $t = 4$, $\mathbf{s} = 21\mathbf{i} + 10\mathbf{j}$. Find

(a) the speed of S , (4)

(b) the direction in which S is moving, giving your answer as a bearing. (2)

(c) Show that $\mathbf{s} = (3t + 9)\mathbf{i} + (4t - 6)\mathbf{j}$. (2)

A lighthouse L is located at the point with position vector $(18\mathbf{i} + 6\mathbf{j})$ km. When $t = T$, the ship S is 10 km from L .

(d) Find the possible values of T . (6)

TOTAL FOR PAPER: 75 MARKS

END

Paper Reference(s)

6677/01

Edexcel GCE

Mechanics M1

Advanced Subsidiary

Monday 24 May 2010 – Morning

Time: 1 hour 30 minutes

Materials required for examination

Mathematical Formulae (Pink)

Items included with question papers

Nil

Candidates may use any calculator allowed by the regulations of the Joint Council for Qualifications. Calculators must not have the facility for symbolic algebra manipulation, differentiation and integration, or have retrievable mathematical formulae stored in them.

Instructions to Candidates

In the boxes on the answer book, write the name of the examining body (Edexcel), your centre number, candidate number, the unit title (Mechanics M1), the paper reference (6677), your surname, other name and signature.

Whenever a numerical value of g is required, take $g = 9.8 \text{ m s}^{-2}$.

When a calculator is used, the answer should be given to an appropriate degree of accuracy.

Information for Candidates

A booklet 'Mathematical Formulae and Statistical Tables' is provided.

Full marks may be obtained for answers to ALL questions.

There are 8 questions in this question paper.

The total mark for this paper is 75.

Advice to Candidates

You must ensure that your answers to parts of questions are clearly labelled.

You must show sufficient working to make your methods clear to the Examiner.

Answers without working may not gain full credit.

1. A particle P is moving with constant velocity $(-3\mathbf{i} + 2\mathbf{j}) \text{ m s}^{-1}$. At time $t = 6 \text{ s}$, P is at the point with position vector $(-4\mathbf{i} - 7\mathbf{j}) \text{ m}$. Find the distance of P from the origin at time $t = 2 \text{ s}$. (5)
-

2. Particle P has mass $m \text{ kg}$ and particle Q has mass $3m \text{ kg}$. The particles are moving in opposite directions along a smooth horizontal plane when they collide directly. Immediately before the collision P has speed $4u \text{ m s}^{-1}$ and Q has speed $ku \text{ m s}^{-1}$, where k is a constant. As a result of the collision the direction of motion of each particle is reversed and the speed of each particle is halved.

(a) Find the value of k .

(4)

(b) Find, in terms of m and u , the magnitude of the impulse exerted on P by Q .

(3)

3.

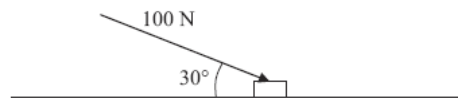

Figure 1

A small box is pushed along a floor. The floor is modelled as a rough horizontal plane and the box is modelled as a particle. The coefficient of friction between the box and the floor is $\frac{1}{2}$. The box is pushed by a force of magnitude 100 N which acts at an angle of 30° with the floor, as shown in Figure 1.

Given that the box moves with constant speed, find the mass of the box.

(7)

4. A beam AB has length 6 m and weight 200 N . The beam rests in a horizontal position on two supports at the points C and D , where $AC = 1 \text{ m}$ and $DB = 1 \text{ m}$. Two children, Sophie and Tom, each of weight 500 N , stand on the beam with Sophie standing twice as far from the end B as Tom. The beam remains horizontal and in equilibrium and the magnitude of the reaction at D is three times the magnitude of the reaction at C . By modelling the beam as a uniform rod and the two children as particles, find how far Tom is standing from the end B .

(7)

5. Two cars P and Q are moving in the same direction along the same straight horizontal road. Car P is moving with constant speed 25 m s^{-1} . At time $t = 0$, P overtakes Q which is moving with constant speed 20 m s^{-1} . From $t = T$ seconds, P decelerates uniformly, coming to rest at a point X which is 800 m from the point where P overtook Q . From $t = 25 \text{ s}$, Q decelerates uniformly, coming to rest at the same point X at the same instant as P .

(a) Sketch, on the same axes, the speed-time graphs of the two cars for the period from $t = 0$ to the time when they both come to rest at the point X .

(4)

(b) Find the value of T .

(8)

6. A ball is projected vertically upwards with a speed of 14.7 m s^{-1} from a point which is 49 m above horizontal ground. Modelling the ball as a particle moving freely under gravity, find

(a) the greatest height, above the ground, reached by the ball,

(4)

(b) the speed with which the ball first strikes the ground,

(3)

(c) the total time from when the ball is projected to when it first strikes the ground.

(3)

7.

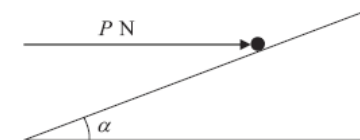

Figure 2

A particle of mass 0.4 kg is held at rest on a fixed rough plane by a horizontal force of magnitude P newtons. The force acts in the vertical plane containing the line of greatest slope of the inclined plane which passes through the particle. The plane is inclined to the horizontal at an angle α , where $\tan \alpha = \frac{3}{4}$, as shown in Figure 2.

The coefficient of friction between the particle and the plane is $\frac{1}{3}$.

Given that the particle is on the point of sliding up the plane, find

(a) the magnitude of the normal reaction between the particle and the plane,

(5)

(b) the value of P .

(5)

8.

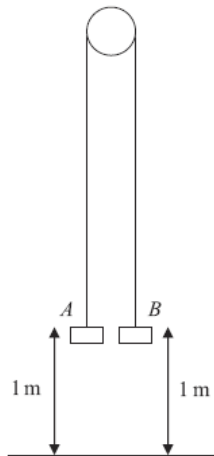

Figure 3

Two particles A and B have mass 0.4 kg and 0.3 kg respectively. The particles are attached to the ends of a light inextensible string. The string passes over a small smooth pulley which is fixed above a horizontal floor. Both particles are held, with the string taut, at a height of 1 m above the floor, as shown in Figure 3. The particles are released from rest and in the subsequent motion B does not reach the pulley.

- (a) Find the tension in the string immediately after the particles are released. (6)
- (b) Find the acceleration of A immediately after the particles are released. (2)
- When the particles have been moving for 0.5 s, the string breaks.
- (c) Find the further time that elapses until B hits the floor. (9)

TOTAL FOR PAPER: 75 MARKS

END

Paper Reference(s)

6677**Edexcel GCE****Mechanics M1****Advanced Subsidiary****Wednesday 19 January 2011 – Afternoon****Time: 1 hour 30 minutes**Materials required for examination

Mathematical Formulae (Pink)

Items included with question papers

Nil

Candidates may use any calculator allowed by the regulations of the Joint Council for Qualifications. Calculators must not have the facility for symbolic algebra manipulation, differentiation and integration, or have retrievable mathematical formulas stored in them.

Instructions to Candidates

In the boxes on the answer book, write the name of the examining body (Edexcel), your centre number, candidate number, the unit title (Mechanics M1), the paper reference (6677), your surname, other name and signature.

Whenever a numerical value of g is required, take $g = 9.8$ m s⁻².

When a calculator is used, the answer should be given to an appropriate degree of accuracy.

Information for Candidates

A booklet 'Mathematical Formulae and Statistical Tables' is provided.

Full marks may be obtained for answers to ALL questions.

There are 7 questions in this question paper.

The total mark for this paper is 75.

Advice to Candidates

You must ensure that your answers to parts of questions are clearly labelled.

You must show sufficient working to make your methods clear to the Examiner.

Answers without working may not gain full credit.

N35407A

This publication may only be reproduced in accordance with Edexcel Limited copyright policy.
©2011 Edexcel Limited.

1. Two particles B and C have mass m kg and 3 kg respectively. They are moving towards each other in opposite directions on a smooth horizontal table. The two particles collide directly. Immediately before the collision, the speed of B is 4 m s^{-1} and the speed of C is 2 m s^{-1} . In the collision the direction of motion of C is reversed and the direction of motion of B is unchanged. Immediately after the collision, the speed of B is 1 m s^{-1} and the speed of C is 3 m s^{-1} .

Find

(a) the value of m , (3)

(b) the magnitude of the impulse received by C . (2)

2. A ball is thrown vertically upwards with speed $u \text{ m s}^{-1}$ from a point P at height h metres above the ground. The ball hits the ground 0.75 s later. The speed of the ball immediately before it hits the ground is 6.45 m s^{-1} . The ball is modelled as a particle.

(a) Show that $u = 0.9$. (3)

(b) Find the height above P to which the ball rises before it starts to fall towards the ground again. (2)

(c) Find the value of h . (3)

3.

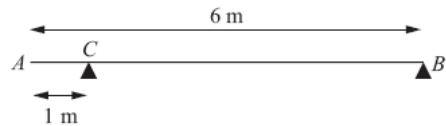

Figure 1

A uniform beam AB has mass 20 kg and length 6 m. The beam rests in equilibrium in a horizontal position on two smooth supports. One support is at C , where $AC = 1 \text{ m}$, and the other is at the end B , as shown in Figure 1. The beam is modelled as a rod.

(a) Find the magnitudes of the reactions on the beam at B and at C . (5)

A boy of mass 30 kg stands on the beam at the point D . The beam remains in equilibrium. The magnitudes of the reactions on the beam at B and at C are now equal. The boy is modelled as a particle.

(b) Find the distance AD . (5)

4. A particle P of mass 2 kg is moving under the action of a constant force \mathbf{F} newtons. The velocity of P is $(2\mathbf{i} - 5\mathbf{j}) \text{ m s}^{-1}$ at time $t = 0$, and $(7\mathbf{i} + 10\mathbf{j}) \text{ m s}^{-1}$ at time $t = 5 \text{ s}$.

Find

(a) the speed of P at $t = 0$, (2)

(b) the vector \mathbf{F} in the form $a\mathbf{i} + b\mathbf{j}$, (5)

(c) the value of t when P is moving parallel to \mathbf{i} . (4)

5. A car accelerates uniformly from rest for 20 seconds. It moves at constant speed $v \text{ m s}^{-1}$ for the next 40 seconds and then decelerates uniformly for 10 seconds until it comes to rest.

(a) For the motion of the car, sketch

(i) a speed-time graph,

(ii) an acceleration-time graph. (6)

Given that the total distance moved by the car is 880 m,

(b) find the value of v . (4)

6.

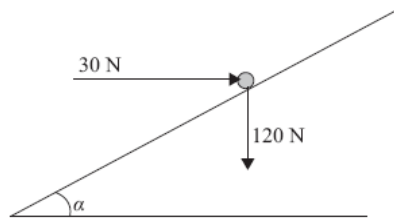

Figure 4

A particle of weight 120 N is placed on a fixed rough plane which is inclined at an angle α to the horizontal, where $\tan \alpha = \frac{3}{4}$.

The coefficient of friction between the particle and the plane is $\frac{1}{2}$.

The particle is held at rest in equilibrium by a horizontal force of magnitude 30 N, which acts in the vertical plane containing the line of greatest slope of the plane through the particle, as shown in Figure 2.

- (a) Show that the normal reaction between the particle and the plane has magnitude 114 N. (4)

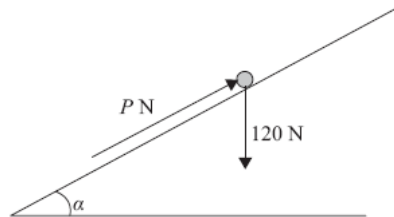

Figure 3

The horizontal force is removed and replaced by a force of magnitude P newtons acting up the slope along the line of greatest slope of the plane through the particle, as shown in Figure 3. The particle remains in equilibrium.

- (b) Find the greatest possible value of P . (8)
- (c) Find the magnitude and direction of the frictional force acting on the particle when $P = 30$. (3)

7.

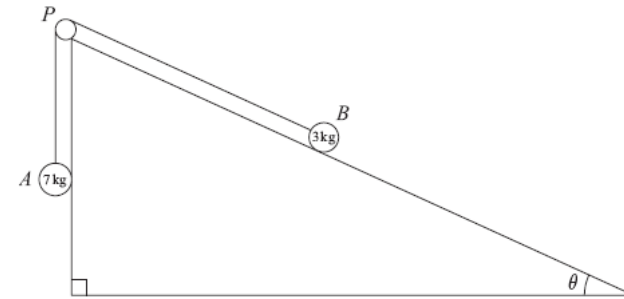

Figure 4

Two particles A and B , of mass 7 kg and 3 kg respectively, are attached to the ends of a light inextensible string. Initially B is held at rest on a rough fixed plane inclined at angle θ to the horizontal, where $\tan \theta = \frac{5}{12}$. The part of the string from B to P is parallel to a line of greatest slope of the plane. The string passes over a small smooth pulley, P , fixed at the top of the plane. The particle A hangs freely below P , as shown in Figure 4. The coefficient of friction between B and the plane is $\frac{2}{3}$. The particles are released from rest with the string taut and B moves up the plane.

- (a) Find the magnitude of the acceleration of B immediately after release. (10)
- (b) Find the speed of B when it has moved 1 m up the plane. (2)

When B has moved 1 m up the plane the string breaks. Given that in the subsequent motion B does not reach P ,

- (c) find the time between the instants when the string breaks and when B comes to instantaneous rest. (4)

TOTAL FOR PAPER: 75 MARKS

END

Paper Reference(s)

6677/01**Edexcel GCE****Mechanics M1****Advanced Subsidiary****Wednesday 18 May 2011 – Morning****Time: 1 hour 30 minutes****Materials required for examination**

Mathematical Formulae (Pink)

Items included with question papers

Nil

Candidates may use any calculator allowed by the regulations of the Joint Council for Qualifications. Calculators must not have the facility for symbolic algebra manipulation, differentiation and integration, or have retrievable mathematical formulae stored in them.

Instructions to Candidates

In the boxes on the answer book, write the name of the examining body (Edexcel), your centre number, candidate number, the unit title (Mechanics M1), the paper reference (6677), your surname, other name and signature.

Whenever a numerical value of g is required, take $g = 9.8 \text{ m s}^{-2}$.

When a calculator is used, the answer should be given to an appropriate degree of accuracy.

Information for Candidates

A booklet 'Mathematical Formulae and Statistical Tables' is provided.

Full marks may be obtained for answers to ALL questions.

There are 7 questions in this question paper.

The total mark for this paper is 75.

Advice to Candidates

You must ensure that your answers to parts of questions are clearly labelled.

You must show sufficient working to make your methods clear to the Examiner.

Answers without working may not gain full credit.

1. At time $t = 0$ a ball is projected vertically upwards from a point O and rises to a maximum height of 40 m above O . The ball is modelled as a particle moving freely under gravity.

(a) Show that the speed of projection is 28 m s^{-1} . (3)

(b) Find the times, in seconds, when the ball is 33.6 m above O . (5)

2. Particle P has mass 3 kg and particle Q has mass 2 kg. The particles are moving in opposite directions on a smooth horizontal plane when they collide directly. Immediately before the collision, P has speed 3 m s^{-1} and Q has speed 2 m s^{-1} . Immediately after the collision, both particles move in the same direction and the difference in their speeds is 1 m s^{-1} .

(a) Find the speed of each particle after the collision. (5)

(b) Find the magnitude of the impulse exerted on P by Q . (3)

- 3.

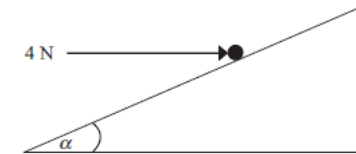

Figure 1

A particle of weight W newtons is held in equilibrium on a rough inclined plane by a horizontal force of magnitude 4 N. The force acts in a vertical plane containing a line of greatest slope of the inclined plane. The plane is inclined to the horizontal at an angle α , where $\tan \alpha = \frac{3}{4}$ as shown in Figure 1.

The coefficient of friction between the particle and the plane is $\frac{1}{2}$.

Given that the particle is on the point of sliding down the plane,

- (i) show that the magnitude of the normal reaction between the particle and the plane is 20 N,
 (ii) find the value of W . (9)

4. A girl runs a 400 m race in a time of 84 s. In a model of this race, it is assumed that, starting from rest, she moves with constant acceleration for 4 s, reaching a speed of 5 m s^{-1} . She maintains this speed for 60 s and then moves with constant deceleration for 20 s, crossing the finishing line with a speed of $V \text{ m s}^{-1}$.
- (a) Sketch a speed-time graph for the motion of the girl during the whole race. (2)
- (b) Find the distance run by the girl in the first 64 s of the race. (3)
- (c) Find the value of V . (5)
- (d) Find the deceleration of the girl in the final 20 s of her race. (2)
-

5. A plank PQR , of length 8 m and mass 20 kg, is in equilibrium in a horizontal position on two supports at P and Q , where $PQ = 6 \text{ m}$.

A child of mass 40 kg stands on the plank at a distance of 2 m from P and a block of mass $M \text{ kg}$ is placed on the plank at the end R . The plank remains horizontal and in equilibrium. The force exerted on the plank by the support at P is equal to the force exerted on the plank by the support at Q .

By modelling the plank as a uniform rod, and the child and the block as particles,

- (a) (i) find the magnitude of the force exerted on the plank by the support at P ,
 (ii) find the value of M . (10)
- (b) State how, in your calculations, you have used the fact that the child and the block can be modelled as particles. (1)
-

6.

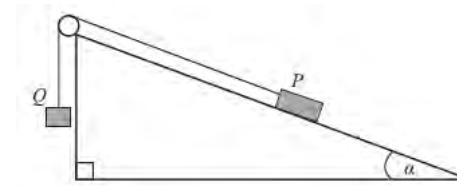

Figure 2

Two particles P and Q have masses 0.3 kg and $m \text{ kg}$ respectively. The particles are attached to the ends of a light inextensible string. The string passes over a small smooth pulley which is fixed at the top of a fixed rough plane. The plane is inclined to the horizontal at an angle α , where $\tan \alpha = \frac{3}{4}$. The coefficient of friction between P and the plane is $\frac{1}{2}$.

The string lies in a vertical plane through a line of greatest slope of the inclined plane. The particle P is held at rest on the inclined plane and the particle Q hangs freely below the pulley with the string taut, as shown in Figure 2.

The system is released from rest and Q accelerates vertically downwards at 1.4 m s^{-2} .

Find

- (a) the magnitude of the normal reaction of the inclined plane on P , (2)
- (b) the value of m . (8)

When the particles have been moving for 0.5 s, the string breaks. Assuming that P does not reach the pulley,

- (c) find the further time that elapses until P comes to instantaneous rest. (6)
-

7. [In this question \mathbf{i} and \mathbf{j} are unit vectors due east and due north respectively. Position vectors are given relative to a fixed origin O .]

Two ships P and Q are moving with constant velocities. Ship P moves with velocity $(2\mathbf{i} - 3\mathbf{j}) \text{ km h}^{-1}$ and ship Q moves with velocity $(3\mathbf{i} + 4\mathbf{j}) \text{ km h}^{-1}$.

- (a) Find, to the nearest degree, the bearing on which Q is moving. (2)

At 2 p.m., ship P is at the point with position vector $(\mathbf{i} + \mathbf{j}) \text{ km}$ and ship Q is at the point with position vector $(-2\mathbf{j}) \text{ km}$.

At time t hours after 2 p.m., the position vector of P is $\mathbf{p} \text{ km}$ and the position vector of Q is $\mathbf{q} \text{ km}$.

- (b) Write down expressions, in terms of t , for

- (i) \mathbf{p} ,
 (ii) \mathbf{q} ,
 (iii) \overline{PQ} . (5)

- (c) Find the time when

- (i) Q is due north of P ,
 (ii) Q is north-west of P . (4)

TOTAL FOR PAPER: 75 MARKS

END

Paper Reference(s)

6677

Edexcel GCE

Mechanics M1

Advanced Subsidiary

Friday 20 January 2012 – Afternoon

Time: 1 hour 30 minutes

Materials required for examination
 Mathematical Formulae (Pink or Green)

Items included with question papers
 Nil

Candidates may use any calculator allowed by the regulations of the Joint Council for Qualifications. Calculators must not have the facility for symbolic algebra manipulation, differentiation and integration, or have retrievable mathematical formulas stored in them.

Instructions to Candidates

In the boxes on the answer book, write the name of the examining body (Edexcel), your centre number, candidate number, the unit title (Mechanics M1), the paper reference (6677), your surname, other name and signature.

Whenever a numerical value of g is required, take $g = 9.8 \text{ m s}^{-2}$.

When a calculator is used, the answer should be given to an appropriate degree of accuracy.

Information for Candidates

A booklet 'Mathematical Formulae and Statistical Tables' is provided.

Full marks may be obtained for answers to ALL questions.

There are 8 questions in this question paper.

The total mark for this paper is 75.

Advice to Candidates

You must ensure that your answers to parts of questions are clearly labelled.

You must show sufficient working to make your methods clear to the Examiner.

Answers without working may not gain full credit.

P40096A

This publication may only be reproduced in accordance with Edexcel Limited copyright policy.
 ©2012 Edexcel Limited.

1. A railway truck P , of mass m kg, is moving along a straight horizontal track with speed 15 m s^{-1} . Truck P collides with a truck Q of mass 3000 kg, which is at rest on the same track. Immediately after the collision the speed of P is 3 m s^{-1} and the speed of Q is 9 m s^{-1} . The direction of motion of P is reversed by the collision.

Modelling the trucks as particles, find

- (a) the magnitude of the impulse exerted by P on Q , (2)
 (b) the value of m . (3)
-

2. A car of mass 1000 kg is towing a caravan of mass 750 kg along a straight horizontal road. The caravan is connected to the car by a tow-bar which is parallel to the direction of motion of the car and the caravan. The tow-bar is modelled as a light rod. The engine of the car provides a constant driving force of 3200 N. The resistances to the motion of the car and the caravan are modelled as constant forces of magnitude 800 newtons and R newtons respectively.

Given that the acceleration of the car and the caravan is 0.88 m s^{-2} ,

- (a) show that $R = 860$, (3)
 (b) find the tension in the tow-bar. (3)
-

3. Three forces \mathbf{F}_1 , \mathbf{F}_2 and \mathbf{F}_3 acting on a particle P are given by

$$\mathbf{F}_1 = (7\mathbf{i} - 9\mathbf{j}) \text{ N}$$

$$\mathbf{F}_2 = (5\mathbf{i} + 6\mathbf{j}) \text{ N}$$

$$\mathbf{F}_3 = (p\mathbf{i} + q\mathbf{j}) \text{ N}$$

where p and q are constants.

Given that P is in equilibrium,

- (a) find the value of p and the value of q . (3)

The force \mathbf{F}_3 is now removed. The resultant of \mathbf{F}_1 and \mathbf{F}_2 is \mathbf{R} . Find

- (b) the magnitude of \mathbf{R} , (2)
 (c) the angle, to the nearest degree, that the direction of \mathbf{R} makes with \mathbf{j} . (3)
-

- 4.

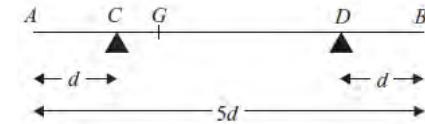

Figure 1

A non-uniform rod AB , of mass m and length $5d$, rests horizontally in equilibrium on two supports at C and D , where $AC = DB = d$, as shown in Figure 1. The centre of mass of the rod is at the point G . A particle of mass $\frac{5}{2}m$ is placed on the rod at B and the rod is on the point of tipping about D .

- (a) Show that $GD = \frac{5}{2}d$. (4)

The particle is moved from B to the mid-point of the rod and the rod remains in equilibrium.

- (b) Find the magnitude of the normal reaction between the support at D and the rod. (5)
-

5. A stone is projected vertically upwards from a point A with speed $u \text{ m s}^{-1}$. After projection the stone moves freely under gravity until it returns to A . The time between the instant that the stone is projected and the instant that it returns to A is $3\frac{4}{7}$ seconds.

Modelling the stone as a particle,

- (a) show that $u = 17\frac{1}{2}$, (3)
 (b) find the greatest height above A reached by the stone, (2)
 (c) find the length of time for which the stone is at least $6\frac{3}{5}$ m above A . (6)
-

6. A car moves along a straight horizontal road from a point A to a point B , where $AB = 885$ m. The car accelerates from rest at A to a speed of 15 m s^{-1} at a constant rate $a \text{ m s}^{-2}$.

The time for which the car accelerates is $\frac{1}{3}T$ seconds. The car maintains the speed of 15 m s^{-1} for T seconds. The car then decelerates at a constant rate of 2.5 m s^{-2} , stopping at B .

- (a) Find the time for which the car decelerates. (2)
- (b) Sketch a speed-time graph for the motion of the car. (2)
- (c) Find the value of T . (4)
- (d) Find the value of a . (2)
- (e) Sketch an acceleration-time graph for the motion of the car. (3)
-

7. [In this question, the unit vectors \mathbf{i} and \mathbf{j} are due east and due north respectively. Position vectors are relative to a fixed origin O .]

A boat P is moving with constant velocity $(-4\mathbf{i} + 8\mathbf{j}) \text{ km h}^{-1}$.

- (a) Calculate the speed of P . (2)

When $t = 0$, the boat P has position vector $(2\mathbf{i} - 8\mathbf{j}) \text{ km}$. At time t hours, the position vector of P is $\mathbf{p} \text{ km}$.

- (b) Write down \mathbf{p} in terms of t . (1)

A second boat Q is also moving with constant velocity. At time t hours, the position vector of Q is $\mathbf{q} \text{ km}$, where

$$\mathbf{q} = 18\mathbf{i} + 12\mathbf{j} - t(6\mathbf{i} + 8\mathbf{j}).$$

Find

- (c) the value of t when P is due west of Q , (3)
- (d) the distance between P and Q when P is due west of Q . (3)
-

8.

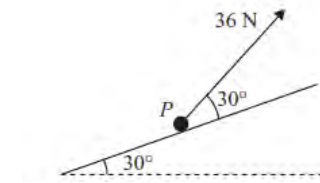

Figure 2

A particle P of mass 4 kg is moving up a fixed rough plane at a constant speed of 16 m s^{-1} under the action of a force of magnitude 36 N . The plane is inclined at 30° to the horizontal. The force acts in the vertical plane containing the line of greatest slope of the plane through P , and acts at 30° to the inclined plane, as shown in Figure 2. The coefficient of friction between P and the plane is μ . Find

- (a) the magnitude of the normal reaction between P and the plane, (4)
- (b) the value of μ . (5)

The force of magnitude 36 N is removed.

- (c) Find the distance that P travels between the instant when the force is removed and the instant when it comes to rest. (5)

TOTAL FOR PAPER: 75 MARKS

END

Paper Reference(s)

6677/01**Edexcel GCE****Mechanics M1****Advanced Subsidiary****Wednesday 16 May 2012 – Morning****Time: 1 hour 30 minutes**Materials required for examination
Mathematical Formulae (Pink)Items included with question papers
Nil

Candidates may use any calculator allowed by the regulations of the Joint Council for Qualifications. Calculators must not have the facility for symbolic algebra manipulation, differentiation and integration, or have retrievable mathematical formulae stored in them.

Instructions to Candidates

In the boxes on the answer book, write the name of the examining body (Edexcel), your centre number, candidate number, the unit title (Mechanics M1), the paper reference (6677), your surname, other name and signature.

Whenever a numerical value of g is required, take $g = 9.8 \text{ m s}^{-2}$.

When a calculator is used, the answer should be given to an appropriate degree of accuracy.

Information for Candidates

A booklet 'Mathematical Formulae and Statistical Tables' is provided.

Full marks may be obtained for answers to ALL questions.

There are 7 questions in this question paper.

The total mark for this paper is 75.

Advice to Candidates

You must ensure that your answers to parts of questions are clearly labelled.

You must show sufficient working to make your methods clear to the Examiner.

Answers without working may not gain full credit.

P40689A

This publication may only be reproduced in accordance with Edexcel Limited copyright policy.
©2012 Edexcel Limited.

1. Two particles A and B , of mass $5m \text{ kg}$ and $2m \text{ kg}$ respectively, are moving in opposite directions along the same straight horizontal line. The particles collide directly. Immediately before the collision, the speeds of A and B are 3 m s^{-1} and 4 m s^{-1} respectively. The direction of motion of A is unchanged by the collision. Immediately after the collision, the speed of A is 0.8 m s^{-1} .

(a) Find the speed of B immediately after the collision.

(3)

In the collision, the magnitude of the impulse exerted on A by B is 3.3 N s .

(b) Find the value of m .

(3)

2.

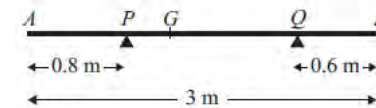
**Figure 1**

A non-uniform rod AB has length 3 m and mass 4.5 kg . The rod rests in equilibrium, in a horizontal position, on two smooth supports at P and at Q , where $AP = 0.8 \text{ m}$ and $QB = 0.6 \text{ m}$, as shown in Figure 1. The centre of mass of the rod is at G . Given that the magnitude of the reaction of the support at P on the rod is twice the magnitude of the reaction of the support at Q on the rod, find

(a) the magnitude of the reaction of the support at Q on the rod,

(3)

(b) the distance AG .

(4)

P40689A

2

3.

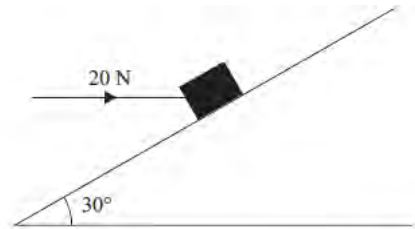

Figure 2

A box of mass 5 kg lies on a rough plane inclined at 30° to the horizontal. The box is held in equilibrium by a horizontal force of magnitude 20 N, as shown in Figure 2. The force acts in a vertical plane containing a line of greatest slope of the inclined plane.

The box is in equilibrium and on the point of moving down the plane. The box is modelled as a particle.

Find

- (a) the magnitude of the normal reaction of the plane on the box, (4)
- (b) the coefficient of friction between the box and the plane. (5)
-

4. A car is moving on a straight horizontal road. At time $t = 0$, the car is moving with speed 20 m s^{-1} and is at the point A . The car maintains the speed of 20 m s^{-1} for 25 s. The car then moves with constant deceleration 0.4 m s^{-2} , reducing its speed from 20 m s^{-1} to 8 m s^{-1} . The car then moves with constant speed 8 m s^{-1} for 60 s. The car then moves with constant acceleration until it is moving with speed 20 m s^{-1} at the point B .

- (a) Sketch a speed-time graph to represent the motion of the car from A to B . (3)
- (b) Find the time for which the car is decelerating. (2)

Given that the distance from A to B is 1960 m,

- (c) find the time taken for the car to move from A to B . (8)
-

5. A particle P is projected vertically upwards from a point A with speed $u \text{ m s}^{-1}$. The point A is 17.5 m above horizontal ground. The particle P moves freely under gravity until it reaches the ground with speed 28 m s^{-1} .

- (a) Show that $u = 21$. (3)

At time t seconds after projection, P is 19 m above A .

- (b) Find the possible values of t . (5)

The ground is soft and, after P reaches the ground, P sinks vertically downwards into the ground before coming to rest. The mass of P is 4 kg and the ground is assumed to exert a constant resistive force of magnitude 5000 N on P .

- (c) Find the vertical distance that P sinks into the ground before coming to rest. (4)
-

6. [In this question \mathbf{i} and \mathbf{j} are horizontal unit vectors due east and due north respectively and position vectors are given with respect to a fixed origin.]

A ship S is moving with constant velocity $(-12\mathbf{i} + 7.5\mathbf{j}) \text{ km h}^{-1}$.

- (a) Find the direction in which S is moving, giving your answer as a bearing. (3)

At time t hours after noon, the position vector of S is \mathbf{s} km. When $t = 0$, $\mathbf{s} = 40\mathbf{i} - 6\mathbf{j}$.

- (b) Write down \mathbf{s} in terms of t . (2)

A fixed beacon B is at the point with position vector $(7\mathbf{i} + 12.5\mathbf{j}) \text{ km}$.

- (c) Find the distance of S from B when $t = 3$. (4)

- (d) Find the distance of S from B when S is due north of B . (4)
-

7.



Figure 3

Two particles P and Q , of mass 0.3 kg and 0.5 kg respectively, are joined by a light horizontal rod. The system of the particles and the rod is at rest on a horizontal plane.

At time $t = 0$, a constant force \mathbf{F} of magnitude 4 N is applied to Q in the direction PQ , as shown in Figure 3. The system moves under the action of this force until $t = 6\text{ s}$. During the motion, the resistance to the motion of P has constant magnitude 1 N and the resistance to the motion of Q has constant magnitude 2 N .

Find

- (a) the acceleration of the particles as the system moves under the action of \mathbf{F} , (3)
- (b) the speed of the particles at $t = 6\text{ s}$, (2)
- (c) the tension in the rod as the system moves under the action of \mathbf{F} . (3)
- At $t = 6\text{ s}$, \mathbf{F} is removed and the system decelerates to rest. The resistances to motion are unchanged. Find
- (d) the distance moved by P as the system decelerates, (4)
- (e) the thrust in the rod as the system decelerates. (3)

TOTAL FOR PAPER: 75 MARKS

END

Paper Reference(s)

6677

Edexcel GCE

Mechanics M1

Advanced Subsidiary

Wednesday 23 January 2013 – Morning

Time: 1 hour 30 minutes

Materials required for examination

Mathematical Formulae (Pink)

Items included with question papers

Nil

Candidates may use any calculator allowed by the regulations of the Joint Council for Qualifications. Calculators must not have the facility for symbolic algebra manipulation, differentiation and integration, or have retrievable mathematical formulas stored in them.

Instructions to Candidates

In the boxes on the answer book, write the name of the examining body (Edexcel), your centre number, candidate number, the unit title (Mechanics M1), the paper reference (6677), your surname, other name and signature.

Whenever a numerical value of g is required, take $g = 9.8\text{ m s}^{-2}$.

When a calculator is used, the answer should be given to an appropriate degree of accuracy.

Information for Candidates

A booklet 'Mathematical Formulae and Statistical Tables' is provided.

Full marks may be obtained for answers to ALL questions.

There are 7 questions in this question paper.

The total mark for this paper is 75.

Advice to Candidates

You must ensure that your answers to parts of questions are clearly labelled.

You must show sufficient working to make your methods clear to the Examiner.

Answers without working may not gain full credit.

P41481A

This publication may only be reproduced in accordance with Edexcel Limited copyright policy.
©2013 Edexcel Limited.

1. Two particles P and Q have masses $4m$ and m respectively. The particles are moving towards each other on a smooth horizontal plane and collide directly. The speeds of P and Q immediately before the collision are $2u$ and $5u$ respectively. Immediately after the collision, the speed of P is $\frac{1}{2}u$ and its direction of motion is reversed.

(a) Find the speed and direction of motion of Q after the collision. (4)

(b) Find the magnitude of the impulse exerted on P by Q in the collision. (3)

2. A steel girder AB , of mass 200 kg and length 12 m, rests horizontally in equilibrium on two smooth supports at C and at D , where $AC = 2$ m and $DB = 2$ m. A man of mass 80 kg stands on the girder at the point P , where $AP = 4$ m, as shown in Figure 1.

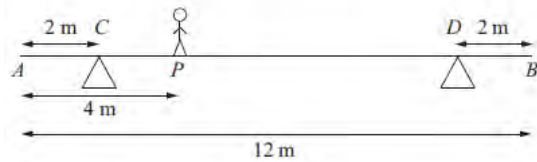

Figure 1

The man is modelled as a particle and the girder is modelled as a uniform rod.

(a) Find the magnitude of the reaction on the girder at the support at C . (3)

The support at D is now moved to the point X on the girder, where $XB = x$ metres. The man remains on the girder at P , as shown in Figure 2.

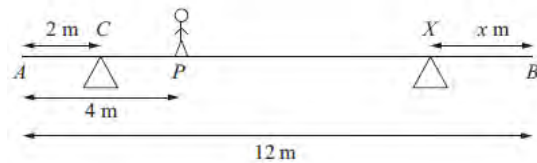

Figure 2

Given that the magnitudes of the reactions at the two supports are now equal and that the girder again rests horizontally in equilibrium, find

(b) the magnitude of the reaction at the support at X , (2)

(c) the value of x . (4)

3. A particle P of mass 2 kg is attached to one end of a light string, the other end of which is attached to a fixed point O . The particle is held in equilibrium, with OP at 30° to the downward vertical, by a force of magnitude F newtons. The force acts in the same vertical plane as the string and acts at an angle of 30° to the horizontal, as shown in Figure 3.

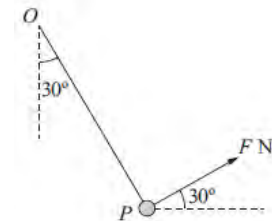

Figure 3

Find

- (i) the value of F ,
 (ii) the tension in the string. (8)
-

4. A lifeboat slides down a straight ramp inclined at an angle of 15° to the horizontal. The lifeboat has mass 800 kg and the length of the ramp is 50 m. The lifeboat is released from rest at the top of the ramp and is moving with a speed of 12.6 m s⁻¹ when it reaches the end of the ramp. By modelling the lifeboat as a particle and the ramp as a rough inclined plane, find the coefficient of friction between the lifeboat and the ramp. (9)
-

5.

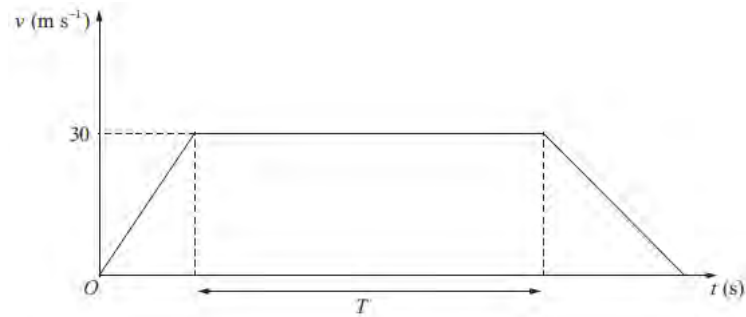

Figure 4

The velocity-time graph in Figure 4 represents the journey of a train P travelling along a straight horizontal track between two stations which are 1.5 km apart. The train P leaves the first station, accelerating uniformly from rest for 300 m until it reaches a speed of 30 m s^{-1} . The train then maintains this speed for T seconds before decelerating uniformly at 1.25 m s^{-2} , coming to rest at the next station.

(a) Find the acceleration of P during the first 300 m of its journey. (2)

(b) Find the value of T . (5)

A second train Q completes the same journey in the same total time. The train leaves the first station, accelerating uniformly from rest until it reaches a speed of $V \text{ m s}^{-1}$ and then immediately decelerates uniformly until it comes to rest at the next station.

(c) Sketch on the diagram above, a velocity-time graph which represents the journey of train Q . (2)

(d) Find the value of V . (6)

6. [In this question, the unit vectors \mathbf{i} and \mathbf{j} are due east and due north respectively. Position vectors are relative to a fixed origin O .]

A ship sets sail at 9 a.m. from a port P and moves with constant velocity. The position vector of P is $(4\mathbf{i} - 8\mathbf{j})$ km. At 9.30 a.m. the ship is at the point with position vector $(\mathbf{i} - 4\mathbf{j})$ km.

(a) Find the speed of the ship in km h^{-1} . (4)

(b) Show that the position vector \mathbf{r} km of the ship, t hours after 9 a.m., is given by

$$\mathbf{r} = (4 - 6t)\mathbf{i} + (8t - 8)\mathbf{j}. \quad (2)$$

At 10 a.m. a passenger on the ship observes that a lighthouse L is due west of the ship.

At 10.30 a.m. the passenger observes that L is now south-west of the ship.

(c) Find the position vector of L . (5)

7.

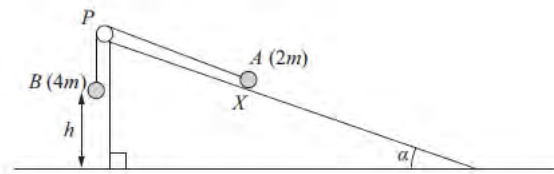

Figure 5

Figure 5 shows two particles A and B , of mass $2m$ and $4m$ respectively, connected by a light inextensible string. Initially A is held at rest on a rough inclined plane which is fixed to horizontal ground. The plane is inclined to the horizontal at an angle α , where $\tan \alpha = \frac{3}{4}$. The coefficient of friction between A and the plane is $\frac{1}{4}$. The string passes over a small smooth pulley P which is fixed at the top of the plane. The part of the string from A to P is parallel to a line of greatest slope of the plane and B hangs vertically below P . The system is released from rest with the string taut, with A at the point X and with B at a height h above the ground.

For the motion until B hits the ground,

- (a) give a reason why the magnitudes of the accelerations of the two particles are the same, (1)
- (b) write down an equation of motion for each particle, (4)
- (c) find the acceleration of each particle. (5)
- Particle B does not rebound when it hits the ground and A continues moving up the plane towards P . Given that A comes to rest at the point Y , without reaching P ,
- (d) find the distance XY in terms of h . (6)

TOTAL FOR PAPER: 75 MARKS

END

Paper Reference(s)

6677/01R

Edexcel GCE

Mechanics M1

Advanced Subsidiary

Monday 13 May 2013 – Afternoon

Time: 1 hour 30 minutes

Materials required for examination

Mathematical Formulae (Pink)

Items included with question papers

Nil

Candidates may use any calculator allowed by the regulations of the Joint Council for Qualifications. Calculators must not have the facility for symbolic algebra manipulation, differentiation and integration, or have retrievable mathematical formulae stored in them.

Instructions to Candidates

In the boxes on the answer book, write the name of the examining body (Edexcel), your centre number, candidate number, the unit title (Mechanics M1), the paper reference (6677R), your surname, other name and signature.

Whenever a numerical value of g is required, take $g = 9.8 \text{ m s}^{-2}$.

When a calculator is used, the answer should be given to an appropriate degree of accuracy.

Information for Candidates

A booklet 'Mathematical Formulae and Statistical Tables' is provided.

Full marks may be obtained for answers to ALL questions.

There are 8 questions in this question paper.

The total mark for this paper is 75.

Advice to Candidates

You must ensure that your answers to parts of questions are clearly labelled.

You must show sufficient working to make your methods clear to the Examiner.

Answers without working may not gain full credit.

P41828A

This publication may only be reproduced in accordance with Edexcel Limited copyright policy.
©2013 Edexcel Limited.

1. Two particles A and B , of mass 2 kg and 3 kg respectively, are moving towards each other in opposite directions along the same straight line on a smooth horizontal surface. The particles collide directly. Immediately before the collision the speed of A is 5 m s^{-1} and the speed of B is 6 m s^{-1} . The magnitude of the impulse exerted on B by A is 14 N s .

Find

- (a) the speed of A immediately after the collision, (3)
 (b) the speed of B immediately after the collision. (3)
-

2.

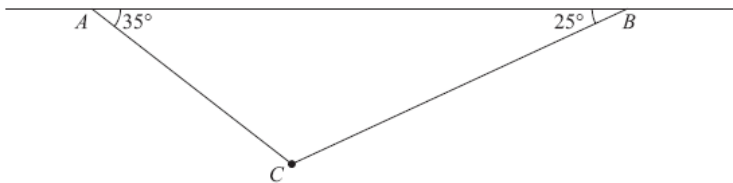

Figure 1

A particle of weight 8 N is attached at C to the ends of two light inextensible strings AC and BC . The other ends, A and B , are attached to a fixed horizontal ceiling. The particle hangs at rest in equilibrium, with the strings in a vertical plane. The string AC is inclined at 35° to the horizontal and the string BC is inclined at 25° to the horizontal, as shown in Figure 1.

Find

- (i) the tension in the string AC ,
 (ii) the tension in the string BC . (8)
-

3.

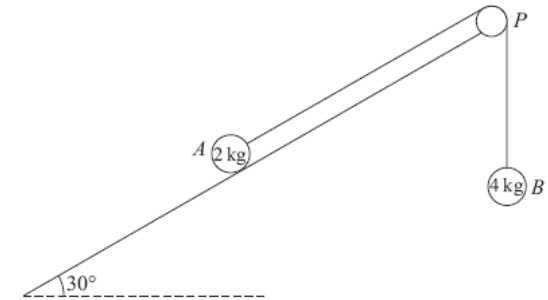

Figure 2

A fixed rough plane is inclined at 30° to the horizontal. A small smooth pulley P is fixed at the top of the plane. Two particles A and B , of mass 2 kg and 4 kg respectively, are attached to the ends of a light inextensible string which passes over the pulley P . The part of the string from A to P is parallel to a line of greatest slope of the plane and B hangs freely below P , as shown in Figure 2. The coefficient of friction between A and the plane is $\frac{1}{\sqrt{3}}$. Initially A is held at rest on the plane. The particles are released from rest with the string taut and A moves up the plane.

Find the tension in the string immediately after the particles are released.

(9)

4. At time $t = 0$, two balls A and B are projected vertically upwards. The ball A is projected vertically upwards with speed 2 m s^{-1} from a point 50 m above the horizontal ground. The ball B is projected vertically upwards from the ground with speed 20 m s^{-1} . At time $t = T$ seconds, the two balls are at the same vertical height, h metres, above the ground. The balls are modelled as particles moving freely under gravity.

Find

- (a) the value of T , (5)
 (b) the value of h . (2)
-

5.

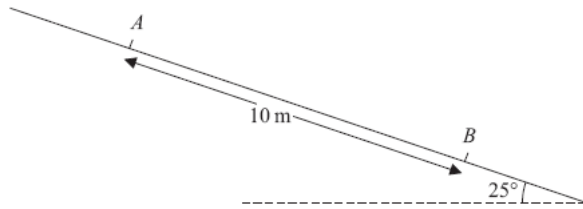

Figure 3

A particle P of mass 0.6 kg slides with constant acceleration down a line of greatest slope of a rough plane, which is inclined at 25° to the horizontal. The particle passes through two points A and B , where $AB = 10$ m, as shown in Figure 3. The speed of P at A is 2 m s $^{-1}$. The particle P takes 3.5 s to move from A to B .

Find

- (a) the speed of P at B , (3)
- (b) the acceleration of P , (2)
- (c) the coefficient of friction between P and the plane. (5)
-

6. [In this question, the horizontal unit vectors \mathbf{i} and \mathbf{j} are directed due east and due north respectively.]

A ship S is moving with constant velocity $(3\mathbf{i} + 3\mathbf{j})$ km h $^{-1}$. At time $t = 0$, the position vector of S is $(-4\mathbf{i} + 2\mathbf{j})$ km.

- (a) Find the position vector of S at time t hours. (2)

A ship T is moving with constant velocity $(-2\mathbf{i} + n\mathbf{j})$ km h $^{-1}$. At time $t = 0$, the position vector of T is $(6\mathbf{i} + \mathbf{j})$ km. The two ships meet at the point P .

- (b) Find the value of n . (5)
- (c) Find the distance OP . (4)
-

7.

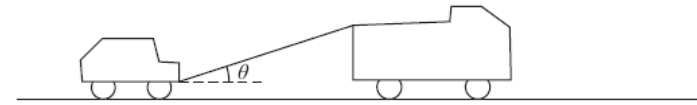

Figure 4

A truck of mass 1750 kg is towing a car of mass 750 kg along a straight horizontal road. The two vehicles are joined by a light towbar which is inclined at an angle θ to the road, as shown in Figure 4. The vehicles are travelling at 20 m s $^{-1}$ as they enter a zone where the speed limit is 14 m s $^{-1}$. The truck's brakes are applied to give a constant braking force on the truck. The distance travelled between the instant when the brakes are applied and the instant when the speed of each vehicle is 14 m s $^{-1}$ is 100 m.

- (a) Find the deceleration of the truck and the car. (3)

The constant braking force on the truck has magnitude R newtons. The truck and the car also experience constant resistances to motion of 500 N and 300 N respectively.

Given that $\cos \theta = 0.9$, find

- (b) the force in the towbar, (4)
- (c) the value of R . (4)
-

8.

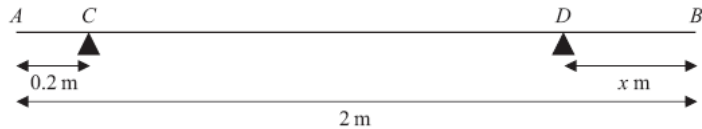

Figure 5

A uniform rod AB has length 2 m and mass 50 kg. The rod is in equilibrium in a horizontal position, resting on two smooth supports at C and D , where $AC = 0.2$ metres and $DB = x$ metres, as shown in Figure 5. Given that the magnitude of the reaction on the rod at D is twice the magnitude of the reaction on the rod at C ,

(a) find the value of x .

(6)

The support at D is now moved to the point E on the rod, where $EB = 0.4$ metres. A particle of mass m kg is placed on the rod at B , and the rod remains in equilibrium in a horizontal position. Given that the magnitude of the reaction on the rod at E is four times the magnitude of the reaction on the rod at C ,

(b) find the value of m .

(7)

TOTAL FOR PAPER: 75 MARKS

END

Paper Reference(s)

6677/01**Edexcel GCE****Mechanics M1****Advanced Subsidiary****Monday 13 May 2013 – Afternoon****Time: 1 hour 30 minutes**Materials required for examination

Mathematical Formulae (Pink)

Items included with question papers

Nil

Candidates may use any calculator allowed by the regulations of the Joint Council for Qualifications. Calculators must not have the facility for symbolic algebra manipulation, differentiation and integration, or have retrievable mathematical formulae stored in them.

Instructions to Candidates

In the boxes on the answer book, write the name of the examining body (Edexcel), your centre number, candidate number, the unit title (Mechanics M1), the paper reference (6677), your surname, other name and signature.

Whenever a numerical value of g is required, take $g = 9.8 \text{ m s}^{-2}$.

When a calculator is used, the answer should be given to an appropriate degree of accuracy.

Information for Candidates

A booklet 'Mathematical Formulae and Statistical Tables' is provided.

Full marks may be obtained for answers to ALL questions.

There are 8 questions in this question paper.

The total mark for this paper is 75.

Advice to Candidates

You must ensure that your answers to parts of questions are clearly labelled.

You must show sufficient working to make your methods clear to the Examiner.

Answers without working may not gain full credit.

1. Particle P has mass 3 kg and particle Q has mass $m \text{ kg}$. The particles are moving in opposite directions along a smooth horizontal plane when they collide directly. Immediately before the collision, the speed of P is 4 m s^{-1} and the speed of Q is 3 m s^{-1} . In the collision the direction of motion of P is unchanged and the direction of motion of Q is reversed. Immediately after the collision, the speed of P is 1 m s^{-1} and the speed of Q is 1.5 m s^{-1} .

(a) Find the magnitude of the impulse exerted on P in the collision.

(3)

(b) Find the value of m .

(3)

2. A woman travels in a lift. The mass of the woman is 50 kg and the mass of the lift is 950 kg . The lift is being raised vertically by a vertical cable which is attached to the top of the lift. The lift is moving upwards and has constant deceleration of 2 m s^{-2} . By modelling the cable as being light and inextensible, find

(a) the tension in the cable,

(3)

(b) the magnitude of the force exerted on the woman by the floor of the lift.

(3)

3.

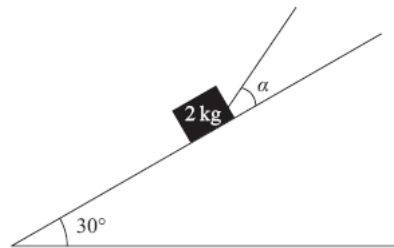

Figure 1

A box of mass 2 kg is held in equilibrium on a fixed rough inclined plane by a rope. The rope lies in a vertical plane containing a line of greatest slope of the inclined plane. The rope is inclined to the plane at an angle α , where $\tan \alpha = \frac{3}{4}$, and the plane is at an angle of 30° to the horizontal, as shown in Figure 1. The coefficient of friction between the box and the inclined plane is $\frac{1}{3}$ and the box is on the point of slipping up the plane. By modelling the box as a particle and the rope as a light inextensible string, find the tension in the rope.

(8)

4. A lorry is moving along a straight horizontal road with constant acceleration. The lorry passes a point A with speed $u \text{ m s}^{-1}$, ($u < 34$), and 10 seconds later passes a point B with speed 34 m s^{-1} . Given that $AB = 240 \text{ m}$, find

(a) the value of u ,

(3)

(b) the time taken for the lorry to move from A to the mid-point of AB .

(6)

5. A car is travelling along a straight horizontal road. The car takes 120 s to travel between two sets of traffic lights which are 2145 m apart. The car starts from rest at the first set of traffic lights and moves with constant acceleration for 30 s until its speed is 22 m s^{-1} . The car maintains this speed for T seconds. The car then moves with constant deceleration, coming to rest at the second set of traffic lights.

(a) Sketch a speed-time graph for the motion of the car between the two sets of traffic lights.

(2)

(b) Find the value of T .

(3)

A motorcycle leaves the first set of traffic lights 10 s after the car has left the first set of traffic lights. The motorcycle moves from rest with constant acceleration, $a \text{ m s}^{-2}$, and passes the car at the point A which is 990 m from the first set of traffic lights. When the motorcycle passes the car, the car is moving with speed 22 m s^{-1} .

(c) Find the time it takes for the motorcycle to move from the first set of traffic lights to the point A .

(4)

(d) Find the value of a .

(2)

6. A beam AB has length 15 m. The beam rests horizontally in equilibrium on two smooth supports at the points P and Q , where $AP = 2$ m and $QB = 3$ m. When a child of mass 50 kg stands on the beam at A , the beam remains in equilibrium and is on the point of tilting about P . When the same child of mass 50 kg stands on the beam at B , the beam remains in equilibrium and is on the point of tilting about Q . The child is modelled as a particle and the beam is modelled as a non-uniform rod.

(a) (i) Find the mass of the beam.

(ii) Find the distance of the centre of mass of the beam from A .

(8)

When the child stands at the point X on the beam, it remains horizontal and in equilibrium. Given that the reactions at the two supports are equal in magnitude,

(b) find AX .

(6)

7. [In this question, the horizontal unit vectors \mathbf{i} and \mathbf{j} are directed due east and due north respectively.]

The velocity, \mathbf{v} m s⁻¹, of a particle P at time t seconds is given by

$$\mathbf{v} = (1 - 2t)\mathbf{i} + (3t - 3)\mathbf{j}.$$

(a) Find the speed of P when $t = 0$.

(3)

(b) Find the bearing on which P is moving when $t = 2$.

(2)

(c) Find the value of t when P is moving

(i) parallel to \mathbf{j} ,

(ii) parallel to $(-\mathbf{i} - 3\mathbf{j})$.

(6)

8.

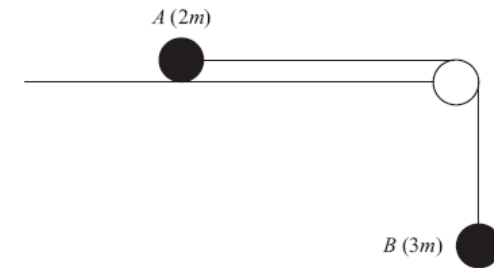

Figure 2

Two particles A and B have masses $2m$ and $3m$ respectively. The particles are attached to the ends of a light inextensible string. Particle A is held at rest on a smooth horizontal table. The string passes over a small smooth pulley which is fixed at the edge of the table. Particle B hangs at rest vertically below the pulley with the string taut, as shown in Figure 2. Particle A is released from rest. Assuming that A has not reached the pulley, find

(a) the acceleration of B ,

(5)

(b) the tension in the string,

(1)

(c) the magnitude and direction of the force exerted on the pulley by the string.

(4)

TOTAL FOR PAPER: 75 MARKS

END

Paper Reference(s)

WME01/01

Pearson Edexcel

International Advanced Level

Mechanics M1

Advanced/Advanced Subsidiary

Wednesday 22 January 2014 – Morning

Time: 1 hour 30 minutes

Materials required for examination

Mathematical Formulae (Blue)

Items included with question papers

Nil

Candidates may use any calculator allowed by the regulations of the Joint Council for Qualifications. Calculators must not have the facility for symbolic algebra manipulation, differentiation and integration, or have retrievable mathematical formulae stored in them.

Instructions

- Use **black** ink or ball-point pen.
- If pencil is used for diagrams/sketches/graphs it must be dark (HB or B). Coloured pencils and highlighter pens must not be used.
- **Fill in the boxes** at the top of this page with your name, centre number and candidate number.
- Answer **all** questions and ensure that your answers to parts of questions are clearly labelled.
- Answer the questions in the spaces provided
– *there may be more space than you need.*
- You should show sufficient working to make your methods clear. Answers without working may not gain full credit.
- Whenever a numerical value of g is required, take $g = 9.8 \text{ m s}^{-2}$, and give your answer to either two significant figures or three significant figures.
- When a calculator is used, the answer should be given to an appropriate degree of accuracy.

Information

- The total mark for this paper is 75.
- The marks for **each** question are shown in brackets
– *use this as a guide as to how much time to spend on each question.*

Advice

- Read each question carefully before you start to answer it.
- Try to answer every question.
- Check your answers if you have time at the end.

P43012A

This publication may only be reproduced in accordance with Edexcel Limited copyright policy.

©2014 Edexcel Limited.

1. A truck P of mass $2M$ is moving with speed U on smooth straight horizontal rails. It collides directly with another truck Q of mass $3M$ which is moving with speed $4U$ in the opposite direction on the same rails. The trucks join so that immediately after the collision they move together. By modelling the trucks as particles, find

(a) the speed of the trucks immediately after the collision, (3)

(b) the magnitude of the impulse exerted on P by Q in the collision. (3)

2. A particle P is moving with constant velocity $(2\mathbf{i} - 3\mathbf{j}) \text{ m s}^{-1}$.

(a) Find the speed of P . (2)

The particle P passes through the point A and 4 seconds later passes through the point with position vector $(\mathbf{i} - 4\mathbf{j}) \text{ m}$.

(b) Find the position vector of A . (4)

3. A beam AB has length 15 m and mass 25 kg. The beam is smoothly supported at the point P , where $AP = 8 \text{ m}$. A man of mass 100 kg stands on the beam at a distance of 2 m from A and another man stands on the beam at a distance of 1 m from B . The beam is modelled as a non-uniform rod and the men are modelled as particles. The beam is in equilibrium in a horizontal position with the reaction on the beam at P having magnitude 2009 N. Find the distance of the centre of mass of the beam from A .

(5)

4.

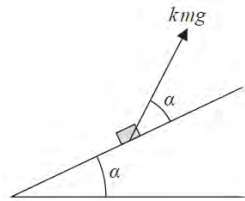

Figure 1

A fixed rough plane is inclined to the horizontal at an angle α , where $\tan \alpha = \frac{3}{4}$.

A small box of mass m is at rest on the plane. A force of magnitude kmg , where k is a constant, is applied to the box. The line of action of the force is at angle α to the line of greatest slope of the plane through the box, as shown in Figure 1, and lies in the same vertical plane as this line of greatest slope. The coefficient of friction between the box and the plane is μ . The box is on the point of slipping up the plane. By modelling the box as a particle, find k in terms of μ .

(11)

5.

A racing car is moving along a straight horizontal track with constant acceleration. There are three checkpoints, P , Q and R , on the track, where $PQ = 48$ m and $QR = 200$ m. The car takes 3 s to travel from P to Q and 5 s to travel from Q to R . Find

- the acceleration of the car,
- the speed of the car as it passes P .

(7)

6.

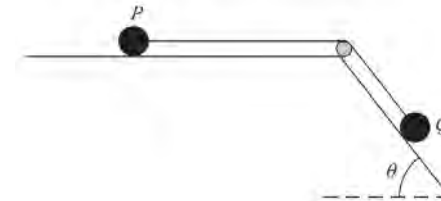

Figure 2

Two particles P and Q have masses 0.1 kg and 0.5 kg respectively. The particles are attached to the ends of a light inextensible string. Particle P is held at rest on a rough horizontal table. The string lies along the table and passes over a small smooth pulley which is fixed to the edge of the table. Particle Q is at rest on a smooth plane which is inclined to the horizontal at an angle θ , where $\tan \theta = \frac{4}{3}$.

The string lies in the vertical plane which contains the pulley and a line of greatest slope of the inclined plane, as shown in Figure 2. Particle P is released from rest with the string taut. During the first 0.5 s of the motion P does not reach the pulley and Q moves 0.75 m down the plane.

- Find the tension in the string during the first 0.5 s of the motion. (6)
- Find the coefficient of friction between P and the table. (5)

7. A force \mathbf{F} is given by $\mathbf{F} = (9\mathbf{i} + 13\mathbf{j})$ N.

- Find the size of the angle between the direction of \mathbf{F} and the vector \mathbf{j} . (3)

The force \mathbf{F} is the resultant of two forces \mathbf{P} and \mathbf{Q} . The line of action of \mathbf{P} is parallel to the vector $(2\mathbf{i} - \mathbf{j})$. The line of action of \mathbf{Q} is parallel to the vector $(\mathbf{i} + 3\mathbf{j})$.

- Find, in terms of \mathbf{i} and \mathbf{j} ,
 - the force \mathbf{P} ,
 - the force \mathbf{Q} .

(9)

8. Two trains, *A* and *B*, start together from rest, at time $t = 0$, at a station and move along parallel straight horizontal tracks. Both trains come to rest at the next station after 180 s.

Train *A* moves with constant acceleration $\frac{2}{3} \text{ m s}^{-2}$ for 30 s, then moves at constant speed for 120 s and then moves with constant deceleration for the final 30 s. Train *B* moves with constant acceleration for 90 s and then moves with constant deceleration for the final 90 s.

- (a) Sketch, on the same axes, the speed–time graphs for the motion of the two trains between the two stations. (3)
- (b) Find the acceleration of train *B* for the first half of its journey. (5)
- (c) Find the times when the two trains are moving at the same speed. (4)
- (d) Find the distance between the trains 96 s after they start. (5)

TOTAL FOR PAPER: 75 MARKS

END

Paper Reference(s)

WME01/01

Pearson Edexcel International Advanced Level

Mechanics M1

Advanced/Advanced Subsidiary

Friday 6 June 2014 – Afternoon

Time: 1 hour 30 minutes

Materials required for examination

Mathematical Formulae (Blue)

Items included with question papers

Nil

Candidates may use any calculator allowed by the regulations of the Joint Council for Qualifications. Calculators must not have the facility for symbolic algebra manipulation, differentiation and integration, or have retrievable mathematical formulae stored in them.

Instructions

- Use **black** ink or ball-point pen.
- If pencil is used for diagrams/sketches/graphs it must be dark (HB or B). Coloured pencils and highlighter pens must not be used.
- **Fill in the boxes** at the top of this page with your name, centre number and candidate number.
- Answer **all** questions and ensure that your answers to parts of questions are clearly labelled.
- Answer the questions in the spaces provided – *there may be more space than you need*.
- You should show sufficient working to make your methods clear. Answers without working may not gain full credit.
- Whenever a numerical value of g is required, take $g = 9.8 \text{ m s}^{-2}$, and give your answer to either two significant figures or three significant figures.
- When a calculator is used, the answer should be given to an appropriate degree of accuracy.

Information

- The total mark for this paper is 75.
- The marks for **each** question are shown in brackets – *use this as a guide as to how much time to spend on each question*.

Advice

- Read each question carefully before you start to answer it.
- Try to answer every question.
- Check your answers if you have time at the end.

P43068A

This publication may only be reproduced in accordance with Pearson Education Limited copyright policy.
©2014 Pearson Education Limited.

1. Two smooth balls A and B have mass 0.6 kg and 0.9 kg respectively. They are moving in a straight line towards each other in opposite directions on a smooth horizontal floor and collide directly. Immediately before the collision the speed of A is v m s⁻¹ and the speed of B is 2 m s⁻¹. The speed of A is 2 m s⁻¹ immediately after the collision and B is brought to rest by the collision.

Find

- (a) the value of v , (3)
- (b) the magnitude of the impulse exerted on A by B in the collision. (2)
-

2. A ball is thrown vertically upwards with speed 20 m s⁻¹ from a point A , which is h metres above the ground. The ball moves freely under gravity until it hits the ground 5 s later.

- (a) Find the value of h . (3)

A second ball is thrown vertically downwards with speed w m s⁻¹ from A and moves freely under gravity until it hits the ground.

The first ball hits the ground with speed V m s⁻¹ and the second ball hits the ground with speed $\frac{3}{4}V$ m s⁻¹.

- (b) Find the value of w . (5)
-

3. A particle P of mass 1.5 kg is placed at point A on a rough plane which is inclined at 30° to the horizontal. The coefficient of friction between P and the plane is 0.6 .

- (a) Show that P rests in equilibrium at A . (5)

A horizontal force of magnitude X newtons is now applied to P , as shown in Figure 1. The force acts in a vertical plane containing a line of greatest slope of the inclined plane.

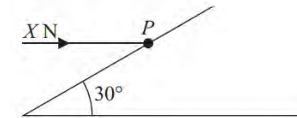

Figure 1

The particle is on the point of moving up the plane.

- (b) Find
- (i) the magnitude of the normal reaction of the plane on P ,
- (ii) the value of X . (7)
-

4.

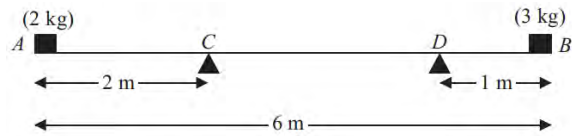

Figure 2

A plank AB , of length 6 m and mass 4 kg, rests in equilibrium horizontally on two supports at C and D , where $AC = 2$ m and $DB = 1$ m. A brick of mass 2 kg rests on the plank at A and a brick of mass 3 kg rests on the plank at B , as shown in Figure 2. The plank is modelled as a uniform rod and all bricks are modelled as particles.

(a) Find the magnitude of the reaction exerted on the plank

- (i) by the support at C ,
- (ii) by the support at D .

(6)

The 3 kg brick is now removed and replaced with a brick of mass x kg at B . The plank remains horizontal and in equilibrium but the reactions on the plank at C and at D now have equal magnitude.

(b) Find the value of x .

(4)

5. [In this question \mathbf{i} and \mathbf{j} are horizontal unit vectors due east and due north respectively. Position vectors are given relative to a fixed origin O .]

A boy B is running in a field with constant velocity $(3\mathbf{i} - 2\mathbf{j})$ m s⁻¹. At time $t = 0$, B is at the point with position vector $10\mathbf{j}$ m.

Find

- (a) the speed of B , (2)
- (b) the direction in which B is running, giving your answer as a bearing. (3)

At time $t = 0$, a girl G is at the point with position vector $(4\mathbf{i} - 2\mathbf{j})$ m. The girl is running with constant velocity $\left(\frac{5}{3}\mathbf{i} + 2\mathbf{j}\right)$ m s⁻¹ and meets B at the point P .

(c) Find

- (i) the value of t when they meet,
- (ii) the position vector of P .

(6)

6. A car starts from rest at point A and moves along a straight horizontal road. The car moves with constant acceleration 1.5 m s⁻² for the first 8 s. The car then moves with constant acceleration 0.8 m s⁻² for the next 20 s. It then moves with constant speed for T seconds before slowing down with constant deceleration 2.8 m s⁻² until it stops at a point B .

- (a) Find the speed of the car 28 s after leaving A . (3)
- (b) Sketch a speed–time graph to illustrate the motion of the car as it travels from A to B . (2)
- (c) Find the distance travelled by the car during the first 28 s of its journey from A . (4)

The distance from A to B is 2 km.

(d) Find the value of T .

(4)

7.

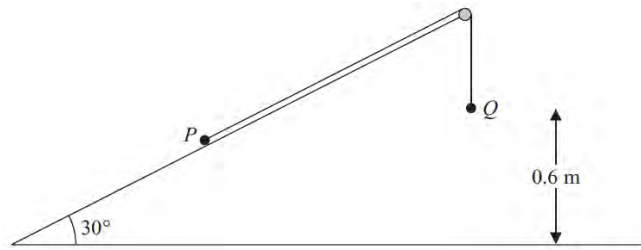

Figure 3

Two particles P and Q , of mass 2 kg and 3 kg respectively, are connected by a light inextensible string. Initially P is held at rest on a fixed smooth plane inclined at 30° to the horizontal. The string passes over a small smooth fixed pulley at the top of the plane. The particle Q hangs freely below the pulley and 0.6 m above the ground, as shown in Figure 3. The part of the string from P to the pulley is parallel to a line of greatest slope of the plane. The system is released from rest with the string taut.

For the motion before Q hits the ground,

- (a) (i) show that the acceleration of Q is $\frac{2g}{5}$,
 (ii) find the tension in the string. (8)

On hitting the ground Q is immediately brought to rest by the impact.

- (b) Find the speed of P at the instant when Q hits the ground. (2)

In its subsequent motion P does not reach the pulley.

- (c) Find the total distance moved up the plane by P before it comes to instantaneous rest. (4)
 (d) Find the length of time between Q hitting the ground and P first coming to instantaneous rest. (2)

TOTAL FOR PAPER: 75 MARKS

END

Paper Reference(s)

6677/01R

Edexcel GCE

Mechanics M1 (R)

Advanced/Advanced Subsidiary

Friday 6 June 2014 – Afternoon

Time: 1 hour 30 minutes

Materials required for examination

Mathematical Formulae (Pink)

Items included with question papers

Nil

Candidates may use any calculator allowed by the regulations of the Joint Council for Qualifications. Calculators must not have the facility for symbolic algebra manipulation or symbolic differentiation/integration, or have retrievable mathematical formulae stored in them.

This paper is strictly for students outside the UK.

Instructions to Candidates

Write the name of the examining body (Edexcel), your centre number, candidate number, the unit title (Mechanics M1), the paper reference (6677R), your surname, initials and signature. Whenever a numerical value of g is required, take $g = 9.8 \text{ m s}^{-2}$. When a calculator is used, the answer should be given to an appropriate degree of accuracy.

Information for Candidates

A booklet 'Mathematical Formulae and Statistical Tables' is provided. Full marks may be obtained for answers to ALL questions. The marks for the parts of questions are shown in round brackets, e.g. (2). There are 7 questions in this question paper. The total mark for this paper is 75.

Advice to Candidates

You must ensure that your answers to parts of questions are clearly labelled. You must show sufficient working to make your methods clear to the Examiner. Answers without working may not gain full credit.

1.

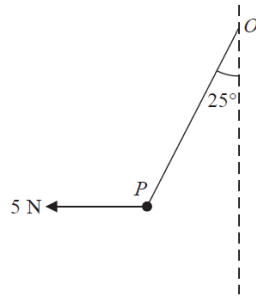

Figure 1

A particle P of weight W newtons is attached to one end of a light inextensible string. The other end of the string is attached to a fixed point O . A horizontal force of magnitude 5 N is applied to P . The particle P is in equilibrium with the string taut and with OP making an angle of 25° to the downward vertical, as shown in Figure 1.

Find

- (a) the tension in the string, (3)
 - (b) the value of W . (3)
-

2. Two forces $(4\mathbf{i} - 2\mathbf{j})\text{ N}$ and $(2\mathbf{i} + q\mathbf{j})\text{ N}$ act on a particle P of mass 1.5 kg . The resultant of these two forces is parallel to the vector $(2\mathbf{i} + \mathbf{j})$.

- (a) Find the value of q . (4)

At time $t = 0$, P is moving with velocity $(-2\mathbf{i} + 4\mathbf{j})\text{ m s}^{-1}$.

- (b) Find the speed of P at time $t = 2$ seconds. (6)
-

3. A car starts from rest and moves with constant acceleration along a straight horizontal road. The car reaches a speed of $V\text{ m s}^{-1}$ in 20 seconds. It moves at constant speed $V\text{ m s}^{-1}$ for the next 30 seconds, then moves with constant deceleration $\frac{1}{2}\text{ m s}^{-2}$ until it has speed 8 m s^{-1} . It moves at speed 8 m s^{-1} for the next 15 seconds and then moves with constant deceleration $\frac{1}{3}\text{ m s}^{-2}$ until it comes to rest.

- (a) Sketch a speed-time graph for this journey. (3)

In the first 20 seconds of this journey the car travels 140 m .

Find

- (b) the value of V , (2)
 - (c) the total time for this journey, (4)
 - (d) the total distance travelled by the car. (4)
-

4. At time $t = 0$, a particle is projected vertically upwards with speed u from a point A . The particle moves freely under gravity. At time T the particle is at its maximum height H above A .

- (a) Find T in terms of u and g . (2)
- (b) Show that $H = \frac{u^2}{2g}$. (2)

The point A is at a height $3H$ above the ground.

- (c) Find, in terms of T , the total time from the instant of projection to the instant when the particle hits the ground. (4)
-

5.

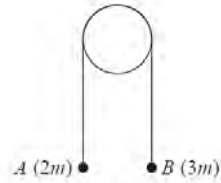

Figure 2

Two particles A and B have masses $2m$ and $3m$ respectively. The particles are connected by a light inextensible string which passes over a smooth light fixed pulley. The system is held at rest with the string taut. The hanging parts of the string are vertical and A and B are above a horizontal plane, as shown in Figure 2. The system is released from rest.

- (a) Show that the tension in the string immediately after the particles are released is $\frac{12}{5}mg$. (6)

After descending 1.5 m, B strikes the plane and is immediately brought to rest. In the subsequent motion, A does not reach the pulley.

- (b) Find the distance travelled by A between the instant when B strikes the plane and the instant when the string next becomes taut. (6)

Given that $m = 0.5$ kg,

- (c) find the magnitude of the impulse on B due to the impact with the plane. (2)

6.

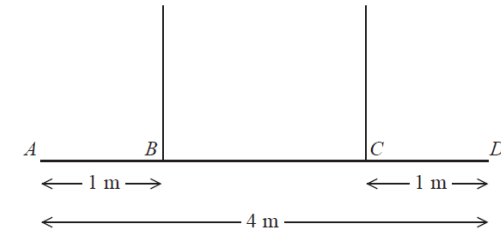

Figure 3

A non-uniform beam AD has weight W newtons and length 4 m. It is held in equilibrium in a horizontal position by two vertical ropes attached to the beam. The ropes are attached to two points B and C on the beam, where $AB = 1$ m and $CD = 1$ m, as shown in Figure 3. The tension in the rope attached to C is double the tension in the rope attached to B . The beam is modelled as a rod and the ropes are modelled as light inextensible strings.

- (a) Find the distance of the centre of mass of the beam from A . (6)

A small load of weight kW newtons is attached to the beam at D . The beam remains in equilibrium in a horizontal position. The load is modelled as a particle.

Find

- (b) an expression for the tension in the rope attached to B , giving your answer in terms of k and W , (3)
- (c) the set of possible values of k for which both ropes remain taut. (2)

7.

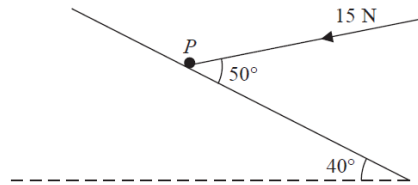

Figure 4

A particle P of mass 2.7 kg lies on a rough plane inclined at 40° to the horizontal. The particle is held in equilibrium by a force of magnitude 15 N acting at an angle of 50° to the plane, as shown in Figure 4. The force acts in a vertical plane containing a line of greatest slope of the plane. The particle is in equilibrium and is on the point of sliding down the plane.

Find

(a) the magnitude of the normal reaction of the plane on P , (4)

(b) the coefficient of friction between P and the plane. (5)

The force of magnitude 15 N is removed.

(c) Determine whether P moves, justifying your answer. (4)

TOTAL FOR PAPER: 75 MARKS

END

Paper Reference(s)

6677/01

Edexcel GCE

Mechanics M1

Advanced/Advanced Subsidiary

Friday 6 June 2014 – Afternoon

Time: 1 hour 30 minutes

Materials required for examination

Mathematical Formulae (Pink)

Items included with question papers

Nil

Candidates may use any calculator allowed by the regulations of the Joint Council for Qualifications. Calculators must not have the facility for symbolic algebra manipulation, differentiation and integration, or have retrievable mathematical formulae stored in them.

Instructions to Candidates

In the boxes on the answer book, write the name of the examining body (Edexcel), your centre number, candidate number, the unit title (Mechanics M1), the paper reference (6677), your surname, other name and signature.

Whenever a numerical value of g is required, take $g = 9.8 \text{ m s}^{-2}$.

When a calculator is used, the answer should be given to an appropriate degree of accuracy.

Information for Candidates

A booklet 'Mathematical Formulae and Statistical Tables' is provided.

Full marks may be obtained for answers to ALL questions.

There are 7 questions in this question paper.

The total mark for this paper is 75.

Advice to Candidates

You must ensure that your answers to parts of questions are clearly labelled.

You must show sufficient working to make your methods clear to the Examiner.

Answers without working may not gain full credit.

P43169A

This publication may only be reproduced in accordance with Pearson Education Limited copyright policy.
©2014 Pearson Education Limited.

1.

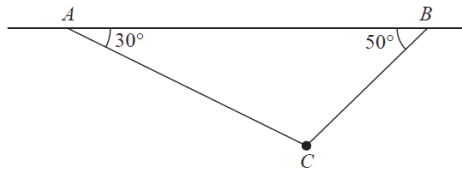

Figure 1

A particle of weight W newtons is attached at C to two light inextensible strings AC and BC . The other ends of the strings are attached to fixed points A and B on a horizontal ceiling. The particle hangs in equilibrium with AC and BC inclined to the horizontal at 30° and 50° respectively, as shown in Figure 1.

Given that the tension in BC is 6 N , find

- (a) the tension in AC , (3)
- (b) the value of W . (3)
-

2.

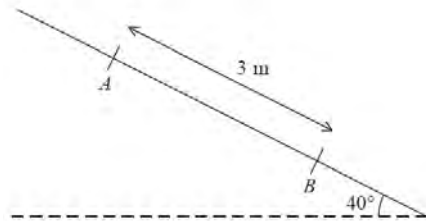

Figure 2

A rough plane is inclined at 40° to the horizontal. Two points A and B are 3 metres apart and lie on a line of greatest slope of the inclined plane, with A above B , as shown in Figure 2. A particle P of mass $m\text{ kg}$ is held at rest on the plane at A . The coefficient of friction between P and the plane is $\frac{1}{2}$. The particle is released.

- (a) Find the acceleration of P down the plane. (5)
- (b) Find the speed of P at B . (2)
-

3. A ball of mass 0.3 kg is released from rest at a point which is 2 m above horizontal ground. The ball moves freely under gravity. After striking the ground, the ball rebounds vertically and rises to a maximum height of 1.5 m above the ground, before falling to the ground again. The ball is modelled as a particle.

- (a) Find the speed of the ball at the instant before it strikes the ground for the first time. (2)
- (b) Find the speed of the ball at the instant after it rebounds from the ground for the first time. (2)
- (c) Find the magnitude of the impulse on the ball in the first impact with the ground. (2)
- (d) Sketch, in the space provided, a velocity-time graph for the motion of the ball from the instant when it is released until the instant when it strikes the ground for the second time. (3)
- (e) Find the time between the instant when the ball is released and the instant when it strikes the ground for the second time. (4)
-

4.

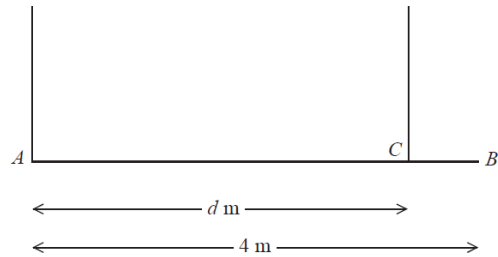

Figure 3

A beam AB has weight W newtons and length 4 m. The beam is held in equilibrium in a horizontal position by two vertical ropes attached to the beam. One rope is attached to A and the other rope is attached to the point C on the beam, where $AC = d$ metres, as shown in Figure 3. The beam is modelled as a uniform rod and the ropes as light inextensible strings. The tension in the rope attached at C is double the tension in the rope attached at A .

(a) Find the value of d . (6)

A small load of weight kW newtons is attached to the beam at B . The beam remains in equilibrium in a horizontal position. The load is modelled as a particle. The tension in the rope attached at C is now four times the tension in the rope attached at A .

(b) Find the value of k . (6)

5. A particle P of mass 0.5 kg is moving under the action of a single force $(3\mathbf{i} - 2\mathbf{j})$ N.

(a) Show that the magnitude of the acceleration of P is $2\sqrt{13}\text{ m s}^{-2}$. (4)

At time $t = 0$, the velocity of P is $(\mathbf{i} + 3\mathbf{j})\text{ m s}^{-1}$.

(b) Find the velocity of P at time $t = 2$ seconds. (3)

Another particle Q moves with constant velocity $\mathbf{v} = (2\mathbf{i} - \mathbf{j})\text{ m s}^{-1}$.

(c) Find the distance moved by Q in 2 seconds. (2)

(d) Show that at time $t = 3.5$ seconds both particles are moving in the same direction. (3)

6.

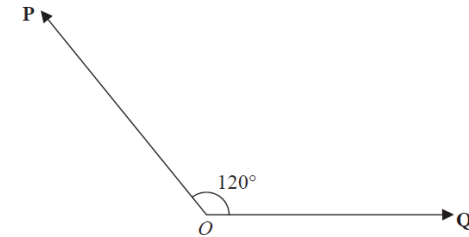

Figure 4

Two forces \mathbf{P} and \mathbf{Q} act on a particle at O . The angle between the lines of action of \mathbf{P} and \mathbf{Q} is 120° as shown in Figure 4. The force \mathbf{P} has magnitude 20 N and the force \mathbf{Q} has magnitude X newtons. The resultant of \mathbf{P} and \mathbf{Q} is the force \mathbf{R} .

Given that the magnitude of \mathbf{R} is $3X$ newtons, find, giving your answers to 3 significant figures,

(a) the value of X , (5)

(b) the magnitude of $(\mathbf{P} - \mathbf{Q})$. (4)

7.

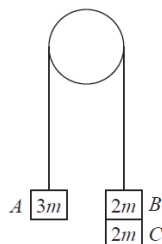

Figure 5

Three particles A , B and C have masses $3m$, $2m$ and $2m$ respectively. Particle C is attached to particle B . Particles A and B are connected by a light inextensible string which passes over a smooth light fixed pulley. The system is held at rest with the string taut and the hanging parts of the string vertical, as shown in Figure 5. The system is released from rest and A moves upwards.

(a) (i) Show that the acceleration of A is $\frac{8}{7}g$.

(ii) Find the tension in the string as A ascends.

(7)

At the instant when A is 0.7 m above its original position, C separates from B and falls away. In the subsequent motion, A does not reach the pulley.

(b) Find the speed of A at the instant when it is 0.7 m above its original position.

(2)

(c) Find the acceleration of A at the instant after C separates from B .

(4)

(d) Find the greatest height reached by A above its original position.

(3)

TOTAL FOR PAPER: 75 MARKS

END